

CITY OF LINCOLN
REGULAR CITY COUNCIL MEETING
AGENDA
JUNE 17, 2019
CITY HALL COUNCIL CHAMBERS
7:00 pm

- 1. Call to Order**
- 2. Roll Call**
- 3. Pledge of Allegiance**
- 4. Public Participation**
- 5. Consent Agenda by Omnibus Vote**

All items under the Consent Agenda are considered to be routine in nature and/or non-controversial and will be approved by one motion. If any one wishes to have a separate vote on any item, it will be pulled from the Consent Agenda and voted on separately.

- A. Payment of Bills
 - B. Approval of minutes June 3, 2019 Regular City Council Meeting
 - C. Mayoral Proclamation declaring the week of June 23, 2019 through June 28, 2019 as Independent Order of Odd Fellows of Illinois week
 - D. Request from City of Lincoln Third Friday Committee to permit the closing of various streets on Friday, July 19, 2019 and Friday, August 23, 2019 for Third Friday events
 - E. Request from the Alley-Bi Saloon to permit the closing of Pulaski Street from 415 Pulaski Street to the alley on Friday, June 21, 2019 from 4:00 PM until 10:00 PM for a block party
 - F. Request from James Cosby to permit the closing of the 200 Block of Pekin Street from College Ave. to North Ottawa Street on Saturday, July 27, 2019 from 4:00 PM until 10:00 PM for a block party.
 - G. Request from Chances R to permit the closing of Peoria Street between N. Chicago Street and UPRR tracks for parking of motorcycles from June 29, 2019 at 11:00 AM until June 30, 2019 at 11:00 AM (block party in parking lot June 29th from 5:00PM – 10:00PM. in conjunction with I ride for Maynard fundraiser Band from 6:00PM – 10:00PM)
 - H. Request from First Presbyterian Church to permit the rerouting of the alley between Ottawa Street and Kankakee Street behind Lincoln Jr High to one-way Eastbound and the rerouting of Ottawa Street between Pekin Street and the alley to one-way Southbound on Wednesday, July 17, 2019 from 4:00 PM until 7:00 PM for the Annual Pork BBQ
- 6. Bids**
 - 7. Reports**
 - A. City Treasurer Report for May, 2019
 - B. City Clerks Report for May, 2019
 - C. Department Head Reports for May, 2019
 - 8. New Business/Communications**
 - A. Approval of the Preliminary Scarification/Oil & Chip Targets for F.Y. 2019-2020
 - B. Approval of the purchase of eight (8) new trucks for the Police Department from Lincoln Chrysler Dodge Jeep Ram not to exceed \$202,352.00
 - 9. Ordinance and Resolution**
 - A. Ordinance amending Title 3, Section 15 Part 1 of the city code to change the legal age of sale and possession of nicotine products and alternative nicotine products to the age of Twenty-One (21)
 - B. Ordinance amending the Appropriation Ordinance for F.Y. 2018-2019
 - 10. Announcements**
 - 11. Executive Session 2 (C) (11)**
 - 12. Adjournment**

We welcome the participation of persons with disabilities at all City of Lincoln meetings. If auxiliary aid or service is required for most effective participation and communication, please notify the City Clerk's Office at 217-735-2815 or cityclerk@lincolnil.gov no later than 48 hours prior to the meeting time.

REGULAR CITY COUNCIL MEETING

Lincoln City Hall, Council Chambers
700 Broadway Street | Lincoln, Illinois

Presiding:

Mayor Seth Goodman

The Regular Meeting of the City Council of Lincoln was called to order by Mayor Seth Goodman at 7:03 p.m., with proper notice given. City Clerk Peggy Bateman called roll.

Present:

Alderman Tracy Welch, Ward 1
Alderman Kathryn Schmidt, Ward 2
Alderman Sam Downs, Ward 2
Alderman Kevin Bateman, Ward 3
Alderman Ron Keller, Ward 3
Alderman Kathy Horn, Ward 4
Alderman Jeff Hoinacki, Ward 4

Staff Present:

City Administrator Elizabeth Kavelman
City Attorney John Hoblit
City Clerk Peggy Bateman
Treasurer Chuck Conzo
Fire Chief Bob Dunovsky
Police Chief Paul Adams
Building and Safety Officer Wes Woodhall
Streets Superintendent Walt Landers

Absent:

Alderman Steve Parrott, Ward 1
Veolia Water, Greg Pyles

Public Comment:

Mayor Goodman called upon citizens registered to speak. Mr. Michael Moore of 6100 Green Valley Road, Clinton, Illinois came forward to discuss Run for Life – to raise \$30,000 for teen suicide awareness. He said the group has raised about \$5,000 already. The race will be November 2, starting at 9 a.m. It will be mostly on pavement – in Weldon Springs State Park in Clinton, Ill.

Next, Fire Chief Bob Dunovsky came forward with Rookie Firefighter James Cosby. He was presented with a new shield. Chief Dunovsky sang his praises. Saying a new firefighter will receive his old shield.

Next, Police Chief Paul Adams came forward to be sworn into his role as Chief of Police in the City of Lincoln.

A. Payment of Bills

B. Approval of minutes May 14, 2019 Regular Committee of the Whole Meeting, May 20, 2019 Regular City Council Meeting, May 28, 2019 Regular Committee of the Whole Meeting

C. Request from LCHS to permit the closing of various city streets for the LCHS Homecoming Parade of Friday, September 20, 2019 from 2:30 p.m. until its conclusion

Alderman Keller made a motion to approve, seconded by Alderman Welch. Alderwoman Horn asked if there was insurance on file. It had not expired yet. Alderman Welch asked about the route. Mr. Landers

said he had a call-in to Mr. Hammer, he said he assumed they could come up with an alternative route if necessary. Mayor Goodman called for further discussion, there being none, City Clerk Bateman called roll.

Yeas: (7) Alderman Tracy Welch, Alderman Kathryn Schmidt, Alderman Sam Downs, Alderman Ron Keller, Alderman Kevin Bateman, Alderman Jeff Hoinacki, Alderman Kathy Horn

Nays: (0)

Abstain: (0)

Absent: (1) Alderman Steve Parrott

Mayor Goodman moved to other items on the agenda.

Ordinance and Resolution:

Resolution 2019-387 establishing the participation of the City of Lincoln in the 2020 United States Census

Alderman Horn made a motion to approve, seconded by Alderman Schmidt. Alderman Keller made comment about the database of addresses. He said Mr. Will D'Andrea had been going through that. Mayor Goodman called for further discussion, there being none, City Clerk Bateman called roll.

Yeas: (7) Alderman Tracy Welch, Alderman Kathryn Schmidt, Alderman Sam Downs, Alderman Ron Keller, Alderman Kevin Bateman, Alderman Jeff Hoinacki, Alderman Kathy Horn

Nays: (0)

Abstain: (0)

Absent: (1) Alderman Steve Parrott

Mayor Goodman moved to other items on the agenda.

Reports:

A. City Treasurer's Annual Firefighters Pension Fund Report for F.Y. 2018-2019

B. City Treasurer's Annual Police Pension Fund Report for Fiscal Year 2018-2019

Treasurer Conzo started in on the subtotal relating to investments and a surplus in the account. He said part of the reason there is growth is because the city was able to modify their investment policy in 2017, however, it was not possible prior to that. He mentioned that the checking account balance was lower. He mentioned an annuity and that there's been relatively larger amounts seen in checking, he said not all of it was growth from the stock market.

He said they have avoided taking money out of investments, due the receipts from annuities. He then mentioned the property tax levy and the remains of a flat tax levy. He touched on page two and how expenditures have gone up, there is a cost of living increase built in for annuitants. He mentioned revenues are still under expenses. He talked about what pensions are being paid out—24 pensions and 20 active participants.

He touched on one fund that has reached \$10 million—and retired officers on the police retirement pension board. He said money in the checking is better than it was last year—\$103,000. He said the same applies to the revenue streams.

Alderman Welch made a motion to approve, seconded by Alderman Bateman. Mayor Goodman called for further discussion, there being none, City Clerk Bateman called roll.

Yeas: (7) Alderman Tracy Welch, Alderman Kathryn Schmidt, Alderman Sam Downs, Alderman Ron Keller, Alderman Kevin Bateman, Alderman Jeff Hoinacki, Alderman Kathy Horn

Nays: (0)
Abstain: (0)
Absent: (1) Alderman Steve Parrott

Mayor Goodman moved to other items on the agenda.

New Business/Communication:

A. Advise and consent to the Mayoral appointment of Hannah Fitzpatrick to the Historic Preservation Commission

Alderman Welch made a motion to approve, seconded by Alderman Keller. Mayor Goodman called for further discussion, there being none, City Clerk Bateman called roll.

Yeas: (7) Alderman Tracy Welch, Alderman Kathryn Schmidt, Alderman Sam Downs, Alderman Ron Keller, Alderman Kevin Bateman, Alderman Jeff Hoinacki, Alderman Kathy Horn

Nays: (0)
Abstain: (0)
Absent: (1) Alderman Steve Parrott

Mayor Goodman moved to other items on the agenda.

B. Approval of agreement for Animal Control Service between Logan County and the City of Lincoln in an amount not to exceed \$42,000

Alderman Bateman made a motion to approve, seconded by Alderman Schmidt. Mayor Goodman called for further discussion, there being none, City Clerk Bateman called roll.

Yeas: (7) Alderman Tracy Welch, Alderman Kathryn Schmidt, Alderman Sam Downs, Alderman Ron Keller, Alderman Kevin Bateman, Alderman Jeff Hoinacki, Alderman Kathy Horn

Nays: (0)
Abstain: (0)
Absent: (1) Alderman Steve Parrott

Mayor Goodman moved to other items on the agenda.

C. Approval of agreement for Professional Services with the Farnsworth Group for the Kickapoo Street Construction project and the Oil and Chip program no to exceed \$42,700

Alderman Hoinacki made a motion to approve . . . Alderman Bateman wanted to know if they would highlight and underline not to exceed. Mr. Landers said he reached out the Joe Adams of Farnsworth and that they are very confident in the estimate. The motion was seconded by Alderman Welch. Mayor Goodman called for further discussion, there being none, City Clerk Bateman called roll.

Yeas: (7) Alderman Tracy Welch, Alderman Kathryn Schmidt, Alderman Sam Downs, Alderman Ron Keller, Alderman Kevin Bateman, Alderman Jeff Hoinacki, Alderman Kathy Horn

Nays: (0)
Abstain: (0)
Absent: (1) Alderman Steve Parrott

Mayor Goodman moved to other items on the agenda.

D. Approval of three-year contract between the Association of Firefighters Union Local 3092 and the City of Lincoln for the period from May 1, 2019 through April 30, 2022

Alderman Hoinacki made a motion to approve, seconded by Alderman Horn. Alderman Bateman said he wanted to abstain from the next two votes as he is not involved in negotiations for the contracts. Mayor Goodman called for further discussion, there being none, City Clerk Bateman called roll.

Yeas: (6) Alderman Tracy Welch, Alderman Kathryn Schmidt, Alderman Sam Downs, Alderman Ron Keller, Alderman Jeff Hoinacki, Alderman Kathy Horn

Nays: (0)

Abstain: (1) Alderman Kevin Bateman

Absent: (1) Alderman Steve Parrott

Mayor Goodman moved to other items on the agenda.

E. Approval of three-year contract between International Union of Operating Engineers Local 399/Street Department and the City of Lincoln for the period from May 1, 2019 Through April 30, 2022

Alderman Welch made a motion to approve, seconded by Alderman Horn. Mayor Goodman called for further discussion, there being none, City Clerk Bateman called roll.

Yeas: (6) Alderman Tracy Welch, Alderman Kathryn Schmidt, Alderman Sam Downs, Alderman Ron Keller, Alderman Jeff Hoinacki, Alderman Kathy Horn

Nays: (0)

Abstain: (1) Alderman Kevin Bateman

Absent: (1) Alderman Steve Parrott

Mayor Goodman moved to other items on the agenda.

Announcements:

Mayor Goodman asked if anyone had any announcements.

- Chief Dunovsky mentioned needing participation for the testing of numerous signals throughout the City of Lincoln. Anyone who hears a signal tomorrow, June 4, at 10 a.m. can contact the chief at 217-737-6709.
- The Mill's 90th Anniversary will be held this weekend along with the Route 66 Garage Sales. There will be an Illinois Route 66 motorcade too. Volunteers will be stamping passports as people leave town. There will also be a 50 Year Ribbon Cutting at Sam Sorrento's Pizzeria at 4 p.m. Friday evening.
- The Abraham Lincoln Hospital will hold a stroke awareness and screening event on June 4. People can call the hospital if they want to attend.
- Alderman Bateman offered a recap of the Pigs and Swigs event. He said there was a record crowd.

Adjournment:

There being no further discussion to come before the City Council of Lincoln, Alderman Welch motioned to adjourn, seconded by Alderman Keller. Roll call was taken. Mayor Goodman adjourned the meeting at 7:44 p.m.

Respectfully Submitted By:

Alex Williams, Recording Secretary

PROCLAMATION

WHEREAS, The Independent Order of Odd Fellows of Illinois in the City of Lincoln have dedicated themselves to the promotion of good will among mankind and to the advancement and betterment of mankind in each city and community in which they exist, and,

WHEREAS, The Independent Order of Odd Fellows this year commemorate their 200th Anniversary on the North American Continent, and their Anniversary in the *State of Illinois*, in the City of Lincoln and,

WHEREAS, The Officers and Members of the Independent Order of Odd Fellows of the State of Illinois in the City of Lincoln, have requested that the week of June 23rd through June 28th, as the Independent Order of Odd Fellows Week,

NOW, THEREFORE, I, Seth Goodman (Mayor) of the State of Illinois in the City of Lincoln, do here by proclaim the above week as.

Independent Order of Odd Fellows

IN WITNESS WHEREOF, I have hereunto set my hand and caused to be affixed the Seal of the State of Illinois in the City of Lincoln, this, the ___ day of June, 2018.

(Mayor)

State of Illinois in the City of Lincoln

REQUEST TO PERMIT

DATE: May 24, 2019

We, the undersigned of the City of Lincoln, do hereby respectfully request the Mayor and City Council to permit

Street closer for 3rd Friday events

Closer of 100 Block N. Kickapoo, 600 Block of Broadway, and Pulaski Street

from the Alley-B1 to the Arcade 4:30 PM - 9:00 PM

2019 Event Date: July 19th

August 23rd (4th Friday) to coincide with Balloon Activities at the Oasis

If the above request is for use of City property, including streets and/ or alleys, please check one of the two boxes below:

A Certificate of Insurance Liability for the event is attached.

A Certificate of Insurance Liability for the event will be provided to the City no later than _____

If City property is used, a Certificate of Insurance Liability is required listing the City as an additional insured. The City reserves the right to postpone review and consideration of this Request to Permit until a Certificate of Insurance Liability is provided.

Name: City of Lincoln - 3rd Friday committee

Address: 700 Broadway Street

Lincoln, IL 62656

Phone: 217-735-2815

Cell: _____

Email: twelch@lincoln.il.gov or pbateman@lincoln.il.gov



CERTIFICATE OF LIABILITY INSURANCE

DATE (MM/DD/YYYY)

4/4/2019

THIS CERTIFICATE IS ISSUED AS A MATTER OF INFORMATION ONLY AND CONFERS NO RIGHTS UPON THE CERTIFICATE HOLDER. THIS CERTIFICATE DOES NOT AFFIRMATIVELY OR NEGATIVELY AMEND, EXTEND OR ALTER THE COVERAGE AFFORDED BY THE POLICIES BELOW. THIS CERTIFICATE OF INSURANCE DOES NOT CONSTITUTE A CONTRACT BETWEEN THE ISSUING INSURER(S), AUTHORIZED REPRESENTATIVE OR PRODUCER, AND THE CERTIFICATE HOLDER.

IMPORTANT: If the certificate holder is an **ADDITIONAL INSURED**, the policy(ies) must have **ADDITIONAL INSURED** provisions or be endorsed. If **SUBROGATION IS WAIVED**, subject to the terms and conditions of the policy, certain policies may require an endorsement. A statement on this certificate does not confer rights to the certificate holder in lieu of such endorsement(s).

PRODUCER Arthur J. Gallagher Risk Management Services, Inc. 2850 Golf Road Rolling Meadows IL 60008	CONTACT NAME: PHONE (A/C, No, Ext): 630-773-3800		FAX (A/C, No): 630-285-4062
	E-MAIL ADDRESS:		
INSURER(S) AFFORDING COVERAGE			NAIC #
INSURER A: Argonaut Great Central Insurance Company			19860
INSURER B:			
INSURER C:			
INSURER D:			
INSURER E:			
INSURER F:			

INSURED LINC10-01
 City of Lincoln, IL
 700 Broadway
 Lincoln IL 62656

COVERAGES **CERTIFICATE NUMBER:** 585172175 **REVISION NUMBER:**

THIS IS TO CERTIFY THAT THE POLICIES OF INSURANCE LISTED BELOW HAVE BEEN ISSUED TO THE INSURED NAMED ABOVE FOR THE POLICY PERIOD INDICATED. NOTWITHSTANDING ANY REQUIREMENT, TERM OR CONDITION OF ANY CONTRACT OR OTHER DOCUMENT WITH RESPECT TO WHICH THIS CERTIFICATE MAY BE ISSUED OR MAY PERTAIN, THE INSURANCE AFFORDED BY THE POLICIES DESCRIBED HEREIN IS SUBJECT TO ALL THE TERMS, EXCLUSIONS AND CONDITIONS OF SUCH POLICIES. LIMITS SHOWN MAY HAVE BEEN REDUCED BY PAID CLAIMS.

INSR LTR	TYPE OF INSURANCE	ADDL SUBR INSD WVD	POLICY NUMBER	POLICY EFF (MM/DD/YYYY)	POLICY EXP (MM/DD/YYYY)	LIMITS
A	<input checked="" type="checkbox"/> COMMERCIAL GENERAL LIABILITY <input type="checkbox"/> CLAIMS-MADE <input checked="" type="checkbox"/> OCCUR GEN'L AGGREGATE LIMIT APPLIES PER: <input checked="" type="checkbox"/> POLICY <input type="checkbox"/> PRO-JECT <input type="checkbox"/> LOC OTHER:		462626307	12/15/2018	12/15/2019	EACH OCCURRENCE \$ 1,000,000 DAMAGE TO RENTED PREMISES (Ea occurrence) \$ 100,000 MED EXP (Any one person) \$ PERSONAL & ADV INJURY \$ 1,000,000 GENERAL AGGREGATE \$ 3,000,000 PRODUCTS - COMP/OP AGG \$ 3,000,000 \$
A	<input checked="" type="checkbox"/> AUTOMOBILE LIABILITY <input checked="" type="checkbox"/> ANY AUTO <input type="checkbox"/> OWNED AUTOS ONLY <input type="checkbox"/> SCHEDULED AUTOS <input type="checkbox"/> HIRED AUTOS ONLY <input checked="" type="checkbox"/> NON-OWNED AUTOS ONLY <input type="checkbox"/> AUTOS ONLY		462626307	12/15/2018	12/15/2019	COMBINED SINGLE LIMIT (Ea accident) \$ 1,000,000 BODILY INJURY (Per person) \$ BODILY INJURY (Per accident) \$ PROPERTY DAMAGE (Per accident) \$ \$
	<input type="checkbox"/> UMBRELLA LIAB <input type="checkbox"/> OCCUR <input type="checkbox"/> EXCESS LIAB <input type="checkbox"/> CLAIMS-MADE <input type="checkbox"/> DED <input type="checkbox"/> RETENTION \$					EACH OCCURRENCE \$ AGGREGATE \$ \$
	WORKERS COMPENSATION AND EMPLOYERS' LIABILITY ANY PROPRIETOR/PARTNER/EXECUTIVE OFFICER/MEMBER EXCLUDED? (Mandatory in MI) If yes, describe under DESCRIPTION OF OPERATIONS below	Y/N	N/A			<input type="checkbox"/> PER STATUTE <input type="checkbox"/> OTH-ER E.L. EACH ACCIDENT \$ E.L. DISEASE - EA EMPLOYEE \$ E.L. DISEASE - POLICY LIMIT \$

DESCRIPTION OF OPERATIONS / LOCATIONS / VEHICLES (ACORD 101, Additional Remarks Schedule, may be attached if more space is required)
 Clayton Holdings, LLC is included as additional insured regarding:
 One (1) NEW 2019 E-One Firetruck - VIN: 4ENLABA82K1001996
 All Aluminum HP100 Rear Mount 100ft Aerial platform mounted on an E-One Cyclone II custom chassis with Cummins ISX12 500hp engine, 300 gallon tank, 1500 gpm Waterous CSU pump, per specifications.

CERTIFICATE HOLDER**CANCELLATION**

SHOULD ANY OF THE ABOVE DESCRIBED POLICIES BE CANCELLED BEFORE THE EXPIRATION DATE THEREOF, NOTICE WILL BE DELIVERED IN ACCORDANCE WITH THE POLICY PROVISIONS.

AUTHORIZED REPRESENTATIVE

© 1988-2015 ACORD CORPORATION. All rights reserved.



CITY OF
LINCOLN, ILLINOIS

City Clerk 700 Broadway St.
217/735-2815 Lincoln, IL 62656

City of Lincoln
Block Party Application

Date Application Submitted: 6/4/19

Name of Block Party Sponsor: Cindy Singleton Phone #: 217-732-3630
Name of Alternate Contact: _____ Phone#: _____

Sponsor's Address: 415 Pulaski E-Mail: gramcindy3@comcast.net
Alternate's Address: _____ E-Mail: _____

Date of Block Party: 6/21/19 Start Time: 5pm End Time: 10pm

Location of Block Party (Specify hundred block, street name from cross street, i.e. 400 Block of Elm from 9th Street to 10th Street) to be ran like 3rd Friday

Block of F Street from Alley
to in front of my establishment for

Do you plan to use a tent? Yes: _____ No: X
Do you plan to have a fire pit? Yes: _____ No: X

Bags & Bee
outside

(Please note that all tents and fire pits must be inspected and approved by Fire Dept. personnel prior to the start of the block party. To schedule a tent or fire pit inspection, contact the Fire Dept. at 735-4020.)

Please Circle Yes or No

Do you request a visit from the Lincoln Fire Department? Yes No

Do you request a visit from the Lincoln Police Department? Yes No

Applicant does hereby promise and agree to indemnify and save harmless the City of Lincoln from any and all claims, demands, causes of action or judgments made by any person and arising in any manner from the granting of Block Party Agreement. The applicant agrees to be responsible for accepting delivery of barricades to their home, for the placement of the barricades upon the City right-of-way and for the return of barricades to their property for City pickup. Any questions in regard to barricades, contact the Street Dept. at 732-4655.

Name (Print): Cindy Singleton

Signature: Cindy Singleton

Note: The Police and or Fire Departments reserve the authority to terminate the event if complaints are received, City ordinances are violated, or if public safety or peace is compromised.

FOR OFFICIAL USE ONLY

Date Received: _____ Application is: Approved: _____ Denied: _____



CITY OF
LINCOLN, ILLINOIS

City Clerk 700 Broadway St.
217/735-2815 Lincoln, IL 62656

City of Lincoln
Block Party Application

Date Application Submitted: 3 June 2019

Name of Block Party Sponsor: James Cosby Phone #: 217-737-0410
Name of Alternate Contact: _____ Phone#: _____

Sponsor's Address: 219 Pekin ST E-Mail: j.cosby.solutions@gmail.com
Alternate's Address: _____ E-Mail: _____

Date of Block Party: 27 July 2019 Start Time: 4:00 pm End Time: 10:00 pm

Location of Block Party (Specify hundred block, street name from cross street, i.e. 400 Block of Elm from 9th Street to 10th Street)

200 Block of Pekin ST from College Ave to
N Ottawa ST

Do you plan to use a tent? Yes: _____ No: X
Do you plan to have a fire pit? Yes: _____ No: X

(Please note that all tents and fire pits must be inspected and approved by Fire Dept. personnel prior to the start of the block party. To schedule a tent or fire pit inspection, contact the Fire Dept. at 735-4020.)

Please Circle Yes or No

Do you request a visit from the Lincoln Fire Department? Yes No

Do you request a visit from the Lincoln Police Department? Yes No

Applicant does hereby promise and agree to indemnify and save harmless the City of Lincoln from any and all claims, demands, causes of action or judgments made by any person and arising in any manner from the granting of Block Party Agreement. The applicant agrees to be responsible for accepting delivery of barricades to their home, for the placement of the barricades upon the City right-of-way and for the return of barricades to their property for City pickup. Any questions in regard to barricades, contact the Street Dept. at 732-4655.

Name (Print): James Cosby

Signature: _____

Note: The Police and or Fire Departments reserve the authority to terminate the event if complaints are received, City ordinances are violated, or if public safety or peace is compromised.

FOR OFFICIAL USE ONLY

Date Received: 6/3/2019 Application is: Approved: _____ Denied: _____

IRR



CITY OF
LINCOLN, ILLINOIS

City Clerk 700 Broadway St.
217/735-2815 Lincoln, IL 62656

**City of Lincoln
Block Party Application.**

Date Application Submitted: 06/11/2019

Name of Block Party Sponsor: Chance's R Phone #: 217-735-1039
 Name of Alternate Contact: Mandy Demling Phone#: 309-275-4853
Stacey Pittman 217-737-3886
 Sponsor's Address: 421 N Chicago St, Lincoln, IL E-Mail: mandydemling@gmail.com
 Alternate's Address: Same E-Mail: pittman s@msn.com

Date of Block Party: 06/29/2019 Start Time: 5:00pm End Time: 10:00pm
 In conjunction with I ride for Maynerd fundraiser Band from 6-10pm
 Location of Block Party (Specify hundred block, street name from cross street, i.e. 400 Block of Elm
 from 9th Street to 10th Street)
421 N Chicago St, Lincoln (in parking lot only) & block Peoria Street
between N Chicago and railroad tracks to use for parking of motorcycles.

*****Would like to keep street blocked off 6/29 11am-6/30 11am for motorcycles left overnight

Do you plan to use a tent? Yes: No: X
 Do you plan to have a fire pit? Yes: No: X

(Please note that all tents and fire pits must be inspected and approved by Fire Dept. personnel prior to the start of the block party. To schedule a tent or fire pit inspection, contact the Fire Dept. at 735-4020.)

Please Circle Yes or No

Do you request a visit from the Lincoln Fire Department? Yes No but are welcome to

Do you request a visit from the Lincoln Police Department? Yes No but are welcome to

Applicant does hereby promise and agree to indemnify and save harmless the City of Lincoln from any and all claims, demands, causes of action or judgments made by any person and arising in any manner from the granting of Block Party Agreement. The applicant agrees to be responsible for accepting delivery of barricades to their home, for the placement of the barricades upon the City right-of-way and for the return of barricades to their property for City pickup. Any questions in regard to barricades, contact the Street Dept. at 732-4655.

Name (Print): Stacey Pittman

Signature:

Note: The Police and or Fire Departments reserve the authority to terminate the event if complaints are received, City ordinances are violated, or if public safety or peace is compromised.

FOR OFFICIAL USE ONLY

Date Received: Application is: Approved: Denied:

REQUEST TO PERMIT

DATE: May 13, 2019

We, the undersigned of the City of Lincoln, do hereby respectfully request the Mayor and City Council to permit

the alley between Ottawa Street and Hankakee Street behind the Lincoln Jr. High School, to be one-way going east on Wednesday, July 17, 2019, between the hours of 4-7pm. In addition, we would like to have Ottawa Street, between Pekin Street and the alley behind the Jr. High, one-way, going south during these same hours. First Presbyterian Church is holding its annual pork BBQ for the 39th year on this date. The size of the BBQ has grown to serve around 700 dinners, over half of which are carry-outs. This one-way traffic flow prevents congestion and accidents. We would also request city barricades to aid with the traffic pattern. We appreciate your consideration of our request. Thank you!

If the above request is for use of City property, including streets and/ or alleys, please check one of the two boxes below:

A Certificate of Insurance Liability for the event is attached.

* Please see diagram on back.

A Certificate of Insurance Liability for the event will be provided to the City no later than _____.

If City property is used, a Certificate of Insurance Liability is required listing the City as an additional insured. The City reserves the right to postpone review and consideration of this Request to Permit until a Certificate of Insurance Liability is provided.

Name: First Presbyterian Church

Address: 301 Pekin Street

Lincoln, IL 62656

Phone: 217-732-7365 Cell: 217-671-3469

Email: kcleesman@frontier.com

BBA Chairs
Charlise Leesman
Deb Schweitzer

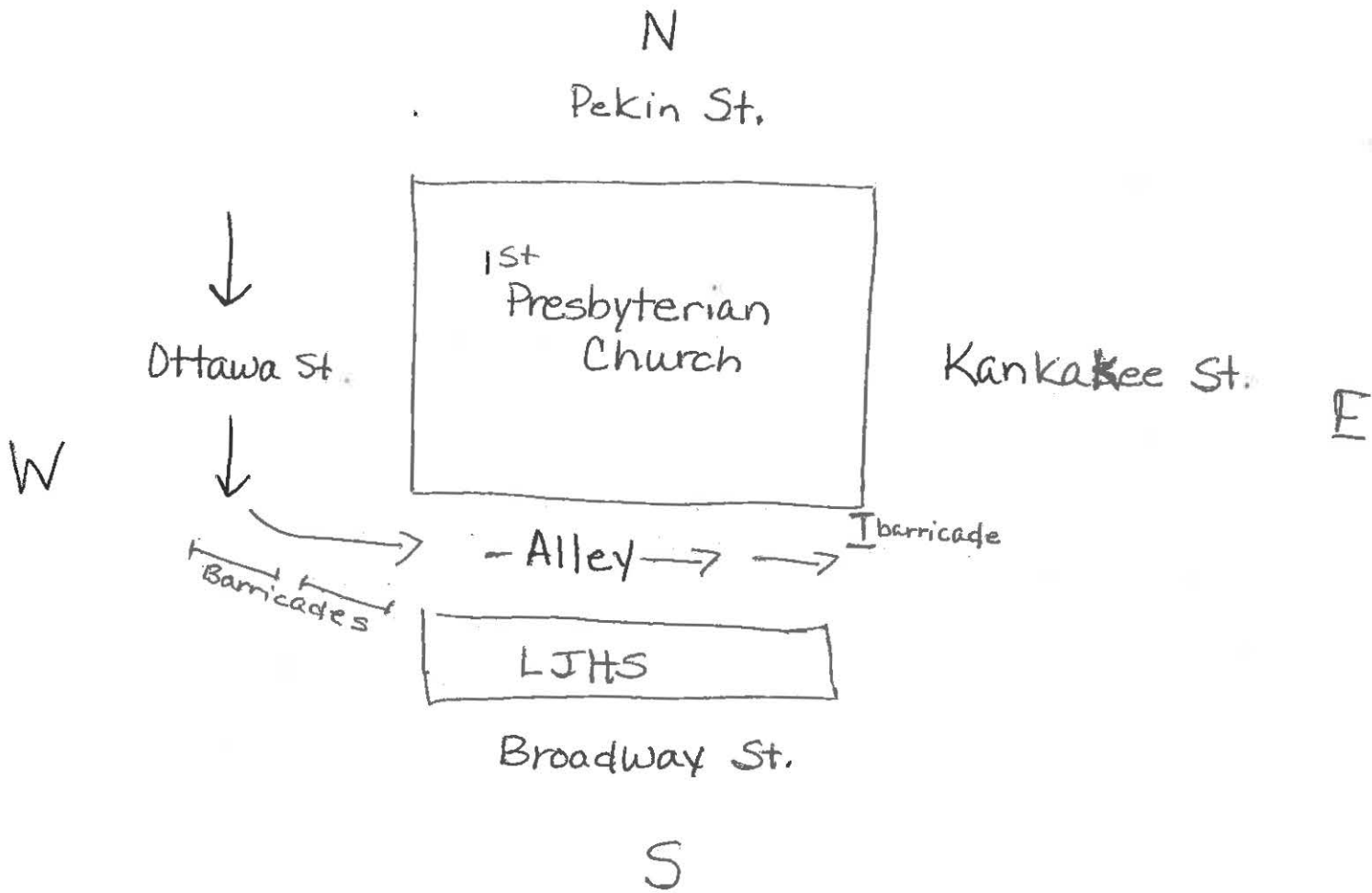



CERTIFICATE OF LIABILITY INSURANCE

DATE (MM/DD/YYYY)

05/08/2019

THIS CERTIFICATE IS ISSUED AS A MATTER OF INFORMATION ONLY AND CONFERS NO RIGHTS UPON THE CERTIFICATE HOLDER. THIS CERTIFICATE DOES NOT AFFIRMATIVELY OR NEGATIVELY AMEND, EXTEND OR ALTER THE COVERAGE AFFORDED BY THE POLICIES BELOW. THIS CERTIFICATE OF INSURANCE DOES NOT CONSTITUTE A CONTRACT BETWEEN THE ISSUING INSURER(S), AUTHORIZED REPRESENTATIVE OR PRODUCER, AND THE CERTIFICATE HOLDER.

IMPORTANT: If the certificate holder is an ADDITIONAL INSURED, the policy(ies) must have ADDITIONAL INSURED provisions or be endorsed. If SUBROGATION IS WAIVED, subject to the terms and conditions of the policy, certain policies may require an endorsement. A statement on this certificate does not confer rights to the certificate holder in lieu of such endorsement(s).

PRODUCER Church Mutual Insurance Company 3000 Schuster Lane P.O. Box 357 Merrill WI 54452	CONTACT NAME: Elizabeth A Swenson PHONE (A/C, No, Ext): 1-800-554-2642 Option 1 E-MAIL ADDRESS: customerservice@churchmutual.com FAX (A/C, No): 855-264-2329
	INSURER(S) AFFORDING COVERAGE INSURER A: Church Mutual Insurance Company INSURER B: INSURER C: INSURER D: INSURER E: INSURER F:
INSURED FIRST PRESBYTERIAN CHURCH 301 PEKIN ST LINCOLN IL 62656-2030	

COVERAGES**CERTIFICATE NUMBER:****REVISION NUMBER:**

THIS IS TO CERTIFY THAT THE POLICIES OF INSURANCE LISTED BELOW HAVE BEEN ISSUED TO THE INSURED NAMED ABOVE FOR THE POLICY PERIOD INDICATED. NOTWITHSTANDING ANY REQUIREMENT, TERM OR CONDITION OF ANY CONTRACT OR OTHER DOCUMENT WITH RESPECT TO WHICH THIS CERTIFICATE MAY BE ISSUED OR MAY PERTAIN, THE INSURANCE AFFORDED BY THE POLICIES DESCRIBED HEREIN IS SUBJECT TO ALL THE TERMS, EXCLUSIONS AND CONDITIONS OF SUCH POLICIES. LIMITS SHOWN MAY HAVE BEEN REDUCED BY PAID CLAIMS.

INSR LTR	TYPE OF INSURANCE	ADDL INSD	SUBR WVD	POLICY NUMBER	POLICY EFF (MM/DD/YYYY)	POLICY EXP (MM/DD/YYYY)	LIMITS
A	<input checked="" type="checkbox"/> COMMERCIAL GENERAL LIABILITY <input type="checkbox"/> CLAIMS-MADE <input checked="" type="checkbox"/> OCCUR GEN'L AGGREGATE LIMIT APPLIES PER: <input checked="" type="checkbox"/> POLICY <input type="checkbox"/> PRO-JECT <input type="checkbox"/> LOC OTHER:	N		0002165-02-174440	01/15/2019	01/15/2022	EACH OCCURRENCE \$ 2,000,000
	DAMAGE TO RENTED PREMISES (Ea occurrence) \$ 1,000,000						
							MED EXP (Any one person) \$ 10,000
							PERSONAL & ADV INJURY \$ 2,000,000
							GENERAL AGGREGATE \$ 5,000,000
							PRODUCTS - COMP/OP AGG \$ 2,000,000
							\$
	AUTOMOBILE LIABILITY <input type="checkbox"/> ANY AUTO <input type="checkbox"/> OWNED AUTOS ONLY <input type="checkbox"/> SCHEDULED AUTOS <input type="checkbox"/> HIRED AUTOS ONLY <input type="checkbox"/> NON-OWNED AUTOS ONLY						COMBINED SINGLE LIMIT (Ea accident) \$
							BODILY INJURY (Per person) \$
							BODILY INJURY (Per accident) \$
							PROPERTY DAMAGE (Per accident) \$
							\$
	UMBRELLA LIAB <input type="checkbox"/> OCCUR EXCESS LIAB <input type="checkbox"/> CLAIMS-MADE DED <input type="checkbox"/> RETENTION \$						EACH OCCURRENCE \$
							AGGREGATE \$
							\$
	WORKERS COMPENSATION AND EMPLOYERS' LIABILITY ANY PROPRIETOR/PARTNER/EXECUTIVE OFFICER/MEMBER EXCLUDED? (Mandatory in NH) if yes, describe under DESCRIPTION OF OPERATIONS below						<input type="checkbox"/> PER STATUTE <input type="checkbox"/> OTH-ER E.L. EACH ACCIDENT \$ E.L. DISEASE - EA EMPLOYEE \$ E.L. DISEASE - POLICY LIMIT \$

DESCRIPTION OF OPERATIONS / LOCATIONS / VEHICLES (ACORD 101, Additional Remarks Schedule, may be attached if more space is required)

CERTIFICATE HOLDER**CANCELLATION**

City of Lincoln - City Hall 701 Broadway St Lincoln IL 62656-2837	SHOULD ANY OF THE ABOVE DESCRIBED POLICIES BE CANCELLED BEFORE THE EXPIRATION DATE THEREOF, NOTICE WILL BE DELIVERED IN ACCORDANCE WITH THE POLICY PROVISIONS.
---	--

MEMORANDUM

TO: Mayor and Aldermen of the City of Lincoln

FROM: Walt Landers, Street Superintendent

MEETING

DATE: June 11, 2019

RE: Preliminary Scarification/Oil & Chip Targets

Background

Each year the Lincoln Street Department Staff and contract engineer Farnsworth Group put together a list of targets for street maintenance to help repair and preserve streets throughout the City.

Analysis/Discussion

Below are a description of the processes used while performing these operations. A/1 being just a surface treatment to seal the roadway and A/2 will actually allow provide base repair and leveling of the driving surface

1. (A/1) - A basic oil and chip coating, this is when a thin layer of oil is applied to the roadway followed by a thin layer of rock to create a wear surface. This seals the roadway and prevents moisture from penetrating and causing damage.
2. (A/2) - The existing roadway is pulverized and regraded then compacted. A primer is then applied and allowed to dry then followed by two layers of oil and chip, the first layer is often a larger stone and the second a finer stone to create a smother driving surface. Often with this process repairs can be made to any base failures that exist.

This is the initial list, once we get cost estimates back for these targets can be added or reduced to fit our budget of approximately \$300,000.00, and the additional \$60,060.00, Reimbursement from Illinois American Water. Once bids are received we can look at adding other targets as long as bids come in under budget. In the past we have asked contractors to hold their unit prices for additional targets and they have always been willing to do so. Logan County Highway Department has also agreed to assist the City with some of these operations so there could be some additional benefit to the program from that agreement.

Fiscal Impact

\$300,000.00, from the Capitol Improvement Fund Cap Exp- Micro Surfacing 60-3600-7827 and \$60,060.00, Reimbursement from Illinois American Water.

COW Recommendation

Approve the Preliminary Scarification/Oil & Chip Targets and place on the June 17, 2019, Regular City Council Meeting Agenda

Council Recommendation:

Approve Preliminary Scarification/Oil & Chip Targets

City of Lincoln - Oil and Chip Targets 2019

Street	From	To	Operation
Ward # 1			
19th St	N Union	Grand	A/1
Palmer Ave	Woodlawn	18th	A/1
	18th St	19th	A/1
	19th St	Bidge	A/1
Clay St	Lincoln	Keokuk	A/2
19th St	Grand Ave	Oglesby	A/2
	Oglesby	Palmer	A/2
Elm St	8th	9th	A/2
	9th	10th	A/2
Ward # 2			
3rd St	Main	Postville	A/1
Jefferson St	5th	6th	A/1
	6th	7th	A/1
	7th	Sht 8th	A/1
	Sht 8th	8th	A/1
Sht 11th	Jefferson	Postville	A/1
Maple	5th	6th	A/2
3rd St	Jefferson	Washington	A/2
	Washington	Main	A/2
Jefferson St	8th	Sht 10th	A/2
	Sht 10th	Sht 11th	A/2
Ward # 3			
Tulip Dr	Miller	Sycamore	A/1
Sycamore Ln	Tulip	Pulkaski	A/1
Campus View Dr	West of LCU Maint. Bldg	Terminus	A/2
College Ave	Pekin	Delavan	A/2
Ward # 4			
Ophir Ave	Logan	Kankakee	A/1

LINCOLN POLICE DEPARTMENT

CHIEF PAUL ADAMS



DEPUTY CHIEF MATT VLAHOVICH

CITY OF LINCOLN
Request for Proposal (RFP)

For
Eight New Patrol Vehicles

City of Lincoln Police Department
710 5th Street, Lincoln, IL

Sealed Proposal Due

4:00p.m., Tuesday, June 11, 2019
Lincoln City Clerk's Office
700 Broadway Street
Lincoln, IL 62656

Questions To

Paul Adams, Police Chief
Or
Matthew Vlahovich, Deputy Chief of Police
City of Lincoln
admin@lincoln.il.gov
217-732-2151

LINCOLN POLICE DEPARTMENT

CHIEF PAUL ADAMS



DEPUTY CHIEF MATT VLAHOVICH

Background

About the City of Lincoln

Located in central Illinois 30 minutes between Springfield to the south and Bloomington to the north. Lincoln's population is just under 15,000 residents, who enjoy a premier quality of life in a small city.

Project Summary

The City of Lincoln invites qualified dealers/vendors to submit responses to this request for proposal (RFP) for, 8 (Eight) - 2019 or newer, half-ton, crew-cab, 4 wheel drive trucks to be utilized as patrol vehicles. Through this RFP, the City is requesting qualified firms to provide itemized pricing and price for each vehicle for purchase of the aforementioned vehicles including the bottom line total price for all eight vehicles including all fees (destination, delivery, prep, title and any license plate transfers).

Content of Proposal

A qualifying proposal must address all of the following points:

1. Cover letter
 - a. Project title "City of Lincoln Police Department, RFP: 8 New Patrol Vehicles"
 - b. Firm Name
 - c. Executive summary
2. Firm Qualifications
 - a. Type of organization, size, professional registration, and affiliations
 - b. Contact information of the principal individual(s) from the firm who will be assisting the City with this initiative
3. Understanding of, and Approach to the Project
 - a. Overall bottom line total price and itemized costs
 - b. Detailed factory warranty with corresponding mileage and any extended warranty options with price.
 - c. Trade-In value of all vehicles listed on Appendix A
 - d. Indication of information and participation required from City staff
 - e. Other information that may be appropriate

LINCOLN POLICE DEPARTMENT

CHIEF PAUL ADAMS



DEPUTY CHIEF MATT VLAHOVICH

Trade in Review

Interested vendors who wish to view the vehicles to be traded or who have questions may make arrangements through Police Chief Paul Adams, or Deputy Chief of Police, Matthew Vlahovich. (Contact information is listed below.)

Scope of Work

The City of Lincoln is seeking qualified vendors to submit proposals for the 8 (Eight) new patrol vehicles, which must meet the following specifications:

- Year 2019 or newer
- 6 Navy blue and 2 granite or the like in color; infused metallic flake in the exterior color is acceptable
- V-8 motor
- 6 or 8 speed, automatic transmission
- 4-wheel-drive
- Crew-Cab
- Chrome bumpers, front and rear
- Aluminum wheels
- All-season tires
- Aluminum, stainless steel or chrome, full cab length step bars
- Spray-in bed liner
- Electronic locking bed-rail boxes for the storage of police equipment
- Tri-fold or the like Tonneau Cover for the bed of the truck
- Black or dark gray cloth 40-20-40 front seats, or simply captain's chairs for the front seats so that a police equipment center console (aftermarket) can be securely installed
- Electric driver's seat adjustment with lumbar
- Black or gray colored rear vinyl bench seat
- Rubber or vinyl floors throughout the interior of the vehicle
- Under the rear seat storage compartments
- Rear floor-board storage compartments
- Factory installed wiring at the four corners of the vehicle for emergency lighting installation
- Factory installed wiring for a driver's side "A" pillar spot light installation
- Rear 2-inch towing receiver and factory trailering wiring
- Back-up camera
- Locking tailgate
- 4 Key fobs & 4 keys
- Keyless entry

LINCOLN POLICE DEPARTMENT

CHIEF PAUL ADAMS



DEPUTY CHIEF MATT VLAHOVICH

- Remote start
- Interior USB remote ports
- Heated side-view mirrors
- Rear window defrost
- Minimum—26 gallon fuel tank
- Minimum—3.21 rear axle ratio
- Full size spare tire and wheel

Submittal Guideline

Respondents are required to submit the following:

- One hard copy proposal in response to the RFP
- Clearly mark the outer envelope “City of Lincoln Police--8 (Eight) New Police Patrol Vehicles”
- Submit all sealed proposals to the following location:

City of Lincoln
City Clerk’s Office
700 Broadway Street
Lincoln Illinois 62656

All questions or requests for additional information should be directed to:

Paul Adams, Police Chief
policechief@lincoln.il.gov
217-732-2151

Matthew Vlahovich, Deputy Chief of Police
dc@lincoln.il.gov
217-732-2151

The City reserves the right to reject any and all proposals. The City will not be liable for, nor pay for any costs incurred by, responding firms relating to the preparation of the proposal. An explicit provision of this RFP is that any oral communication is not binding on the City’s proposal process or award of the contract.

LINCOLN POLICE DEPARTMENT

CHIEF PAUL ADAMS



DEPUTY CHIEF MATT VLAHOVICH

Anticipated RFP and Project Timeline

The projected RFP timeline is anticipated to be as follows:

- May 20th, 2019 - Release of the RFP
- June 11th, 2019 – Sealed RFP due to the City by 4:00 PM
- June 11th, 2019 at 7:00 PM – City Council to open and review RFP responses
- June 17th, 2019 - Selection and approval for RFP by City Council
- June 18th, 2019 – Notification of selected vendor and order of the 8 vehicles.

Selection of Vendor

The City will review and evaluate the proposals submitted based on each responding firm's knowledge, experience, skills, past performance, and quality of the proposal. In addition, the following criteria will also be used in the evaluation process:

1. Demonstrate professional skills and credentials of staff to be assigned to the project
2. Overall cost and fees to be charged
3. Responsiveness to the RFP

The City reserves the right to accept or reject a respondent's proposal, in full or in part, based upon the needs of the City of Lincoln Police Department and the cost effectiveness of the design or the vehicles.

Terms and Conditions

The following terms and conditions apply to this RFP:

1. All responses shall become property of the City of Lincoln.
2. Due care and diligence has been exercised in the preparation of this RFP and all information contained herein is believed to be substantially correct. However, the responsibility for determining the full extent of the services rest solely with those making responses. Neither the City nor its representatives shall be responsible for any error or omission in this response, nor for the failure on the part of the respondents to determine the full extent of their exposures.
3. Proposals will be reviewed for completeness and compliance with all requests and requirements, including proposal instructions, specifications, and terms and conditions of the Proposal. Proposals that fail to comply with the essential

LINCOLN POLICE DEPARTMENT

CHIEF PAUL ADAMS



DEPUTY CHIEF MATT VLAHOVICH

requests and requirements of the RFP may be rejected as non-responsive and eliminated from further consideration.

4. The City reserves the right to select consultants from the responses received; to waive any and all informalities and / or irregularities; to re-advertise with either an identical or revised scope, or to cancel any requirement in its entirety; or to reject any or all proposals received. The City also reserves the right to approve any subcontractor used by submitting firms.
5. A response to this RFP does not constitute a formal bid. Therefore, the City retains the right to contact any / all proposing firms after submittal in order to obtain supplemental information and/or clarification in either oral or written form. Furthermore, an explicit provision of the RFP is that any oral communication made is not binding on the City's proposal process.
6. The City will not be liable for, nor pay for any costs incurred by the responding firms relating to the preparation of any proposal for this RFP.
7. Vendor's signature shall be construed as acceptance of; and willingness to comply with, all provisions of the Illinois Compiled Statutes, Chapter 820, 130/1-130/12, Employment Wages and Hours Prevailing Wage Act. All laborers, workmen and mechanics engaged in construction will be paid not less than the "Prevailing Wage."
8. Tax Exempt: No taxes are to be included in any proposal or proposal price. Generally, states and political subdivisions are exempt from Federal taxes, such as excise and transportation. To the extent any sales, import or other taxes apply they are to be invoiced as a separate item.
9. As City of Lincoln is a government agency, any document submitted in response to this solicitation will not be returned, will become part of the public record, and is subject to the Freedom of Information Act (FOIA) law. As such, proposals may be released to third parties without prior notice to Vendor as required to comply with legal requirements.
10. City of Lincoln purchasing policy is online at <https://lincoln.il.gov> or available from the City Clerk's Office.

LINCOLN POLICE DEPARTMENT

CHIEF PAUL ADAMS



DEPUTY CHIEF MATT VLAHOVICH

CONTRACTOR BID AGREEMENT

TO: City of Lincoln
700 Broadway Street
Lincoln, IL 62656

The undersigned bidder, in compliance with your advertisement for bids for work as specified, and related documents prepared by or at the direction of the City of Lincoln, Owner, and being familiar with all conditions surrounding the work, including availability of labor and material, does hereby propose to furnish materials, labor, equipment and services and pay for same and shall perform all work required for the completion of the Project, in accordance with the Contract documents and at the price provided.

The undersigned bidder understands that prevailing wages must be paid in connection with the work, and agrees to maintain and provide to the owner upon its request, required documentation to support compliance with the Illinois Prevailing Wage Act, in accordance with the law.

Bidder certifies this bid to be for the project described in the Instruction to Bidders document and to be in accordance with plans, specifications and Contract documents, including the invitation for bids. In no event shall any delays or extensions of time be construed as cause or justification for payment of extra compensation to the Contractor. Any claims for an increase of the Contract time shall be made in writing to the City within seven (7) days of the cause.

(Printed name of Contractor)

Address

City State Zip Code

Signature of Authorized Representative

Title Date

LINCOLN POLICE DEPARTMENT

CHIEF PAUL ADAMS



DEPUTY CHIEF MATT VLAHOVICH

**Appendix A
Trade In Vehicles**

Year	Make	Model	Mileage	VIN
2008	Ford	Crown Victoria Police Interceptor	124,982 miles	2FAFP71V18X180424
Notes:	Blue, 4 Door, 4.6 L V-8 Motor			
Trade In Value		\$		

Year	Make	Model	Mileage	VIN
2010	Ford	Crown Victoria Police Interceptor	109,000 miles	2FABP7BV7AX112874
Notes:	Black, 4 Door, 4.6 L V-8 Motor			
Trade In Value		\$		

Year	Make	Model	Mileage	VIN
208	Ford	Crown Victoria Police Interceptor	171,041 miles	2FAFP71V68X128934
Notes:	Black & White, 4 Door, 4.6L V-8 Motor. New motor was installed at 75,000 miles.			
Trade In Value		\$		

LINCOLN POLICE DEPARTMENT

CHIEF PAUL ADAMS



DEPUTY CHIEF MATT VLAHOVICH

Year	Make	Model	Mileage	VIN
2009	Ford	Crown Victoria Police Interceptor	162,000 miles	2FAHP71V99X139632
Notes:	Black & White, 4 Door, 4.6L V-8 Motor			
Trade In Value		\$		

Year	Make	Model	Mileage	VIN
2010	Ford	Crown Victoria Police Interceptor	80,000 miles	2FABP7BV3AX131955
Notes:	Black & White, 4 Door, 4.6 L V-8 Motor			
Trade In Value		\$		

Year	Make	Model	Mileage	VIN
2008	Ford	Explorer	88,000 miles	1FMEU73E18UB17967
Notes:	Brown, 4 Door, 4.0L V-6 Motor			
Trade In Value		\$		

Year	Make	Model	Mileage	VIN
2008	Dodge	Charger	99,000 miles	2B3KA43G78H217902
Notes:	Black, 4 Door Sedan, 3.6L V-6 Motor			
Trade In Value		\$		

LINCOLN POLICE DEPARTMENT

CHIEF PAUL ADAMS



DEPUTY CHIEF MATT VLAHOVICH

Year	Make	Model	Mileage	VIN
2012	Dodge	Charger	83,000 miles	2C3CDXAG3CH126508
Notes:	Black, 4 Door Sedan, 3.6L V-6 Motor			
Trade In Value	\$			

Year	Make	Model	Mileage	VIN
2013	Dodge	Charger	58,000 miles	2C3CDXAG9DH734664
Notes:	Navy Blue, 4 Door Sedan, 3.6L V-6 Motor			
Trade In Value	\$			

LINCOLN POLICE DEPARTMENT

CHIEF OF POLICE PAUL ADAMS



DEPUTY CHIEF MATTHEW VLAHOVICH

To: City of Lincoln Administrator, Beth Kavelman
From: Chief of Police, Paul Adams
Meeting Date: June 17, 2019

Re: Vehicles Bid Authorization

Background

The Council budgeted for the Police Department to purchase eight (8) patrol vehicles to be financed over a three year period. On May 20, 2019, a request for proposal (RFP) was advertised on the City Website and Deputy Chief Vlahovich hand delivered the RFP to the local dealers and sent the RFP via electronic mail to surrounding area dealerships.

Analysis/Discussion

The City Clerk's office received two bids from local dealers with the following pricing:

Lincoln CDJR -	\$221,552 minus \$19,200 for trade-ins = \$202,352 final
Graue Inc -	\$266,904 minus \$11,800 for trade-ins = \$255,104.00 final

Both bids appear to meet the requirements of the RFP. The only discrepancy between the two bids are the vehicle year. Lincoln CDJR indicates 2019 pricing, which is within the RFP requirements and Graue indicated 2020. However looking through the pricing sheet of Graue it listed a 2019 Chevrolet truck and 2019 was crossed out 2020 written in, see attached.

Lincoln CDJR indicated that the last opportunity to order a 2019 is July 20, 2019.

Fiscal Impact

The City budgeted \$78,617 this year and based on financing amount will budget the necessary amount for the following two years to pay the lease for the eight vehicles. If you extend \$78,617 to three years this would total \$235,851.

Once approved the Police department will seek bids for financing for the vehicles which will be approved in subsequent meeting. Given the bid amount from Lincoln CDJR we will be well under budget with financing.

COW Recommendation

Place on Council Agenda for June 17, 2019: Approval to accept the bid from Lincoln Chrysler, Dodge, Jeep, Ram for eight new police vehicles not to exceed \$202,352.

LINCOLN

CHRYSLER • DODGE • JEEP • RAM

City of Lincoln Police Department, RFP

8 New Patrol Vehicles

2019 Ram 1500 Classic Crew Cab 4x4

All requested specifications met.

Factory Warranty:

3 years or 36,000 miles – Basic Warranty

5 years or 60,000 miles – Powertrain Warranty

\$0.00 Deductible

Bid price per Truck - \$27,694.00

8 @ \$27,694.00 = \$221,552.00

9 Trade ins on Appendix A - Total Value - \$19,200

\$221,552.00

-\$ 19,200.00

\$202,352.00 Total plus Title and License

Title & License \$105.00 per vehicle

Lincoln Chrysler Dodge Jeep

103 Taylor Court

Lincoln IL 62656

Scott Soebbing

217-732-1661

ssoebbing@frontier.com

LINCOLN



103 Taylor Court
Lincoln, IL 62656

City of Lincoln Police - 5 New Police Officer Vacancies

CITY CLERK
LINCOLN ILLINOIS

A Davis

JUN 11 2019

10:15 a.m.

RECEIVED

LINCOLN CHRYSLER DODGE & JEEP
 103 TAYLOR COURT
 LINCOLN, IL 626562235

Configuration Preview

Date Printed: 2019-06-06 1:05 PM VIN: Quantity: 1
 Estimated Ship Date: VON: Status: BA - Pending order
 FAN 1: 001MB City of Lincoln, Illir
 FAN 2:
 Client Code:
 Bid Number: TB9063
 PO Number:
 Sold to: Ship to:
 LINCOLN CHRYSLER DODGE & JEEP (45390) LINCOLN CHRYSLER DODGE & JEEP (45390)
 103 TAYLOR COURT 103 TAYLOR COURT
 LINCOLN, IL 626562235 LINCOLN, IL 626562235

Vehicle: 2019 1500 CLASSIC ST CREW CAB 4X4 (140 in WB 5 FT 7 IN box) (DS6L98)

	Sales Code	Description	MSRP(USD)
Model:	DS6L98	1500 CLASSIC ST CREW CAB 4X4 (140 in WB 5 FT 7 IN box)	37,195
Package:	27B	Customer Preferred Package 27B	0
	EZH	3.7L V6 HEMI MDS VVT Engine	1,450
	DFD	3-Spd Auto SHIFTS Trac (Buy)	500
Paint/Seat/Trim:	PAR	Monotone Paint	200
	APA	Monotone Paint	0
	*M9	Cloth 40/20/40 Prem Bench Seat	1,000
	-X8	Black/Diesel Gray	0
Options:	4DH	Prepaid Holdback	0
	4ES	Delivery Allowance Credit	0
	MAF	Fleet Purchase Incentive	0
	XB9	Rear Box Cargo Management System	1,295
	GXM	Remote Keyless Entry with All-Secure	190
	GFA	Rear Window Defroster	195
	CS7	Tri-Fold Tonneau Cover	595
	AJB	Remote Start & Security Alarm Group	395
	AED	Chrome Appearance Group	695
	5N6	Easy Order	0
	4FM	Fleet Option Editor	0
	4FT	Fleet Sales Order	0
	151	Zone 51-Chicago	0
	4EA	Sold Vehicle	0
Non Equipment:	4FA	Special Bid-Ineligible For Incentive	0
Bid Number:	TB9063	Government Incentives	0
Discounts:	YGE	5 Additional Gallons of Gas	0
Destination Fees:			1,695

*OPTIONAL
 ORDERED
 EQUIPMENT*

Total Price: **45,405**

Order Type: Fleet PSP Month/Week: *add steps*
 Scheduling Priority: 1-Sold Order Build Priority: 99
 Salesperson:
 Customer Name:
 Customer Address: USA

Instructions:

Note: This is not an invoice. The prices and equipment shown on this priced order confirmation are tentative and subject to change or correction without prior notice. No claims against the content listed or prices quoted will be accepted. Refer to the vehicle invoice for vehicle content and pricing. Orders are accepted only when the vehicle is shipped by the factory.

Chrome Appearance Group (AED)



Details:

- ✓ • Bright Rear Bumper (MBF)
- ✓ • Body Color Upper Fascia (MCM)
- ✓ • 17X7.0 Aluminum Wheels (WFE)
- ✓ • Bright Grille (MFD)
- ✓ • Bright Front Bumper (MCT)

Remote Keyless Entry with All-Secure (GXM)



- ✓ Remote keyless entry locks and unlocks the doors and tailgate of your vehicle at the touch of a button on your key fob. You can also activate the panic alarm on the fob. The AllSecure® Central Locking System engages your vehicle's theft deterrent system to help protect your entire vehicle. The system even protects the contents of the available RamBox® Cargo Management System.

✓ Full CAB length step bars installed by Lincoln CDTR.

Differences in the DS6T98 and DS6L98

DS6T98	DS6L98
Column Mounted Shifter	Rotary Dial Shifter ✓
3.55 Rear Axle Ratio	3.21 Rear Axle Ratio ✓
220 AMP Alternator	180 AMP Alternator ✓
6 Speed	8 Speed ✓
Vinyl Rear Seats	Vinyl Rear Seats - To be installed by Upfitter ✓
VISM	No VISM but will have front/rear wigwag upfit ✓
4 Key Fobs	2 additional Key Fobs will be provided (4 Total) ✓

*Customers wanting center of 40/20/40 deleted must have D5 option selected on DS6T98 POC

Any questions, please contact your Government Sales Manager.

Factory
Upfit Installation

- ✓ • Dome Light installation
- ✓ • Rear Vinyl Seat
- ✓ • Removal of Center Console (If *D5 Seat is selected)
- ✓ • Module installed on the L98 to allow customers to wig wag front and rear flashers
- ✓ • Certified Speedometer (Not at Upfitter but Letter Available)
- ✓ • 2 Additional Key Fob's
- ✓ • Spot Lamp Pre-Wiring

Code	Description
MSV	"Classic" Badge
JCB	120 MPH Primary Speedometer
JJJ	12V Auxiliary Power Outlet
BAB	160 Amp Alternator
W1A	17" Steel Spare Wheel
WFP	17x7.0 Steel Wheels
DJG	215MM Front Axle
DRN	235MM REAR AXLE
NFW	26 Gallon Fuel Tank
CB9	2nd Row In Floor Storage Bins
DMC	3.21 Rear Axle Ratio
ERB	3.0L V6 24V VVT Engine
SCF	4-Spoke Steering Wheel
CBE	40/20/40 Split Bench Seat
MUS	4X4 Badge
NAS	50 State Emissions
RCG	6 Speakers
XFK	7 Pin Wiring Harness
BCN	730 Amp Maintenance Free Battery
DFL	8-Spd Auto 845RE Trans (Make)
MDX	Active Grille Shutters
CG3	Advanced Multistage Front Air Bags
HAA	Air Conditioning
BRT	Anti-Lock 4-Wheel Disc Brakes
RSU	Audio Jack Input for Mobile Devices
LMG	Automatic Headlamps
NHB	Auxiliary Transmission Oil Cooler
CTL	Base Door Trim Panel
MNA	Black Door Handles
LE4	Black Exterior Mirrors
MB1	Black Front Bumper
MFF	Black Grille
MBN	Black Rear Bumper
CKJ	Black Vinyl Floor Covering
XJ8	Body Color Fuel Filler Door
LPE	Cargo and CHMSL Lamp
WMJ	Center Hub
XFH	Class IV Receiver Hitch
JAE	Cluster 3.5" TFT B&W Display
DS7	Conventional Differential Frt Axle
DS8	Conventional Differential Rear Axle
HGB	Dash Liner Insulation
X82	Door Parts Module

Code	Description
CSP	Driver/Passenger Assist Handles
JJB	Dual Note Electric Horns
DH9	Elec Shift-on-the-Fly P/Time T/Case
XXU	Electronic Shift
BNB	Electronic Stability Control
NHA	Engine Oil Cooler
NHJ	Exterior Mirrors w/Heating Element
RDD	Fixed Long Mast Antenna
HGF	Floor Tunnel Insulation
CDR	Front Armrest w/Three Cupholders
MXC	Front Bumper Sight Shields
X83	Front End Parts Module
SFB	Front Heavy Duty Shock Absorbers
CGD	Front Height Adjust Shoulder Belts
MDA	Front License Plate Bracket
LAX	Front Passenger Seat Belt Alert
SHA	Front Stabilizer Bar
MEN	Front Wheel Spats
TBB	Full Size Spare Tire
Z6D	GVW Rating - 6800#
LME	Halogen Quad Headlamps
*TX	HD Vinyl 40/20/40 Split Bench Seat
LA6	Incandescent Taillamps
JY1	Instrument Cluster Theme 1 (Base)
JBF	Instrument Panel Black Bezel
X81	Instrument Panel Parts Module
XJJ	Locking Tailgate
JP8	Manual Adjust Seats
RS6	Media Hub (USB, Aux)
MCL	Molded-in-Black Upper Fascia
APA	Monotone Paint
CE8	No Lumbar Adjust
XA8	Non Adjustable Pedals
TTM	P265/70R17 BSW All Season Tires
XAC	ParkView Rear Back-Up Camera
XBS	Pickup Box
JKY	Power Accessory Delay
GT6	Power Heated Mirrors, Fold-Away
JPB	Power Locks
SBA	Power Rack and Pinion Steering
JP3	Pwr Front Windows, 1-Touch Up & Down
XFC	R1234YF A/C Refrigerant
RA1	Radio 3.0

Code	Description
MGA	Ram's Head Badge
LCH	Rear Dome Lamp
GJD	Rear Fixed Window
CFM	Rear Folding Seat
SGB	Rear Heavy Duty Shock Absorbers
SHF	Rear Stabilizer Bar
CUE	Rear Underseat Compartment Storage
MPP	Rear Wheel Spats
MHL	Rear Wheel Well Liners
RSX	Remote USB Port
RS3	Remote USB Port - Charge Only
C1G	Rotary Shifter-Black
GN4	RR View Auto Dim Mirror w/Display
X8Z	Seat Parts Module
GXX	Sentry Key Theft Deterrent System
NHM	Speed Control
XMF	Spray in Bedliner
CLY	Storage Tray
CJ2	Supp. Side Curtain Frt/Rr Air Bags
CJ1	Supplemental Frt Seat Side Air Bags
CGS	Supplemental Side Air Bags
SUA	Tilt Steering Column
GAC	Tinted Glass Windows
GBB	Tinted Windshield Glass
XBN	Tip Start
X88	Tire & Wheel Parts Module
TBM	Tire Carrier Winch
XGM	Tire Pressure Monitoring Display
XFU	Trailer Tow w/4-Pin Connector Wiring
JHA	Var Intermittent Windshield Wipers
LAZ	Vehicle Information Center
4ZB	Vendor Painted Cargo Box Tracking

Graue Inc.
1905 N. Kickapoo St.
Lincoln, IL 62656
Franchise dealer of Chevrolet, Buick and Cadillac

6/10/2019

City of Lincoln Police Department, RFP: 8 New Patrol Vehicles

To be ordered.

Eight (8) New 2020 Chevrolet Silverado 1500 4x4 Crew Cab (CK10543

Individual vehicle

MSRP: \$46,695.00

Dealer installed cover \$600.00

Total \$47,295.00

Discounts \$13,932

Delivered Price (including fees) \$33,363

Total for eight: \$266,904

Total Price for the nine trades. \$11,800

Final Price \$255,104.00

Thank you,



Dave Renfro
New Sales Manager

LINCOLN POLICE DEPARTMENT

CHIEF PAUL ADAMS



DEPUTY CHIEF MATT VLAHOVICH

CONTRACTOR BID AGREEMENT

TO: City of Lincoln
700 Broadway Street
Lincoln, IL 62656

The undersigned bidder, in compliance with your advertisement for bids for work as specified, and related documents prepared by or at the direction of the City of Lincoln, Owner, and being familiar with all conditions surrounding the work, including availability of labor and material, does hereby propose to furnish materials, labor, equipment and services and pay for same and shall perform all work required for the completion of the Project, in accordance with the Contract documents and at the price provided.

The undersigned bidder understands that prevailing wages must be paid in connection with the work, and agrees to maintain and provide to the owner upon its request, required documentation to support compliance with the Illinois Prevailing Wage Act, in accordance with the law.

Bidder certifies this bid to be for the project described in the Instruction to Bidders document and to be in accordance with plans, specifications and Contract documents, including the invitation for bids. In no event shall any delays or extensions of time be construed as cause or justification for payment of extra compensation to the Contractor. Any claims for an increase of the Contract time shall be made in writing to the City within seven (7) days of the cause.

GRAVE CHEVROLET

(Printed name of Contractor)

1905 N KICKAPOO

Address

Lincoln

ILL

62656

City

State

Zip Code

Handwritten signature of authorized representative

Signature of Authorized Representative

SALESMANAGER

Title

JUNE 3, 2019

Date

LINCOLN POLICE DEPARTMENT

CHIEF PAUL ADAMS



DEPUTY CHIEF MATT VLAHOVICH

Trade in Review

Interested vendors who wish to view the vehicles to be traded or who have questions may make arrangements through Police Chief Paul Adams, or Deputy Chief of Police, Matthew Vlahovich. (Contact information is listed below.)

Scope of Work

The City of Lincoln is seeking qualified vendors to submit proposals for the 8 (Eight) new patrol vehicles, which must meet the following specifications:

- Year 2019 or newer
- 6 Navy blue and 2 granite or the like in color; infused metallic flake in the exterior color is acceptable
- V-8 motor
- 6 or 8 speed, automatic transmission
- 4-wheel-drive
- Crew-Cab
- Chrome bumpers, front and rear
- Aluminum wheels
- All-season tires
- Aluminum, stainless steel or chrome, full cab length step bars
- Spray-in bed liner
- Electronic locking bed-rail boxes for the storage of police equipment
- Tri-fold or the like Tonneau Cover for the bed of the truck
- Black or dark gray cloth 40-20-40 front seats, or simply captain's chairs for the front seats so that a police equipment center console (aftermarket) can be securely installed
- Electric driver's seat adjustment with lumbar
- Black or gray colored rear vinyl bench seat
- Rubber or vinyl floors throughout the interior of the vehicle
- Under the rear seat storage compartments
- Rear floor-board storage compartments
- Factory installed wiring at the four corners of the vehicle for emergency lighting installation
- Factory installed wiring for a driver's side "A" pillar spot light installation
- Rear 2-inch towing receiver and factory trailering wiring
- Back-up camera
- Locking tailgate
- 4 Key fobs & 4 keys
- Keyless entry

LINCOLN POLICE DEPARTMENT

CHIEF PAUL ADAMS



DEPUTY CHIEF MATT VLAHOVICH

- Remote start
- Interior USB remote ports
- Heated side-view mirrors
- Rear window defrost
- Minimum—26 gallon fuel tank
- Minimum—3.21 rear axle ratio
- Full size spare tire and wheel

Submittal Guideline

Respondents are required to submit the following:

- One hard copy proposal in response to the RFP
- Clearly mark the outer envelope “City of Lincoln Police--8 (Eight) New Police Patrol Vehicles”
- Submit all sealed proposals to the following location:

City of Lincoln
City Clerk's Office
700 Broadway Street
Lincoln Illinois 62656

All questions or requests for additional information should be directed to:

Paul Adams, Police Chief
policechief@lincolnil.gov
217-732-2151

Matthew Vlahovich, Deputy Chief of Police
dc@lincolnil.gov
217-732-2151

The City reserves the right to reject any and all proposals. The City will not be liable for, nor pay for any costs incurred by, responding firms relating to the preparation of the proposal. An explicit provision of this RFP is that any oral communication is not binding on the City's proposal process or award of the contract.

City of Lincoln Police Department, RFP: 8 New Patrol Vehicles

Graue Inc.

1905 N. Kickapoo St.

Lincoln, IL 62656

Franchise dealer of Chevrolet, Buick and Cadillac

Contact:

Dave Renfro, New Vehicle Sales Manager

217-735-4444



2020

[Fleet] ~~2019~~ Chevrolet Silverado 1500 (CK10543) 4WD Crew Cab 147" Work Truck

Window Sticker

SUMMARY

[Fleet] ~~2019~~ Chevrolet Silverado 1500 (CK10543) 4WD Crew Cab 147" Work Truck
2020

MSRP:\$37,900.00

Interior:Jet Black, Cloth seat trim

Exterior 1:Special Exterior Color

Exterior 2:No color has been selected.

Engine, 5.3L EcoTec3 V8

Transmission, 6-speed automatic, electronically controlled

OPTIONS

CODE	MODEL	MSRP
CK10543	2020 [Fleet] 2019 Chevrolet Silverado 1500 (CK10543) 4WD Crew Cab 147" Work Truck	\$37,900.00
OPTIONS		
01U	Special Exterior Color	\$0.00
1WT	Work Truck Preferred Equipment Group	\$0.00
5H1	Key equipment, two additional keys for single key system.	\$45.00
5J1	Calibration, keyless remote panic button exterior lights/horn disable	Inc.
5J3	Calibration, Surveillance Mode Interior & Exterior Lighting	Inc.
5J9	Calibration, Taillamp Flasher, Red/White.	\$75.00
5T5	Seats, Front cloth and second row vinyl	\$0.00
5W4	Special Service Package	\$550.00
A2X	Seat adjuster, driver 10-way power including lumbar	\$290.00
A52	Seats, front 40/20/40 split-bench	\$0.00
AQQ	Remote Keyless Entry, with 2 transmitters	Inc.
C49	Defogger, rear-window electric	\$235.00
C5Y	GVWR, 7100 lbs. (3221 kg)	Inc.
CGN	Chevytec spray-on bedliner, Black with Chevrolet logo	\$545.00
CTT	Hitch Guidance	Inc.
DLF	Mirrors, outside heated power-adjustable	Inc.
FE9	Emissions, Federal requirements	\$0.00
GU6	Rear axle, 3.42 ratio	\$0.00

This document contains information considered Confidential between GM and its Clients uniquely. The Information provided is not intended for public disclosure. Prices, specifications, and availability are subject to change without notice, and do not include certain fees, taxes and charges that may be required by law or vary by manufacturer or region. Performance figures are guidelines only, and actual performance may vary. Photos may not represent actual vehicles or exact configurations. Content based on report preparer's input is subject to the accuracy of the input provided.

Data Version: 8480. Data Updated: Jun 2, 2019 9:30:00 PM PDT.



[Fleet] ~~2019~~ Chevrolet Silverado 1500 (CK10543) 4WD Crew Cab 147" Work Truck
2020

H0U	Jet Black, Cloth seat trim		\$0.00
IOR	Audio system, Chevrolet Infotainment 3 system		\$0.00
K34	Cruise control, electronic	Inc.	
K47	Air cleaner, high-capacity	Inc.	
KC9	Power outlet, bed mounted, 120-volt	Inc.	
K14	Power outlet, instrument panel, 120-volt	Inc.	
KNP	Cooling, auxiliary external transmission oil cooler	Inc.	
KW5	Alternator, 220 amps	Inc.	
L82	Engine, 5.3L EcoTec3 V8		\$1,395.00
MYC	Transmission, 6-speed automatic, electronically controlled		\$0.00
Q5U	Wheels, 17" x 8" (43.2 cm x 20.3 cm) Bright Silver painted aluminum	Inc.	
QBN	Tires, 255/70R17 all-season, blackwall		\$0.00
QT5	Tailgate, gate function manual	Inc.	
R13	WT Appearance Package		\$550.00
RW9	LPO, Bedside storage boxes, full-length		\$995.00
TGK	Special Paint		\$450.00
V46	Bumper, front chrome	Inc.	
VBJ	LPO, Underseat storage		\$255.00
VJH	Bumper, rear chrome	Inc.	
VQ2	Fleet Processing Option		\$0.00
VXH	LPO, Assist steps, chromed tubular, 6" rectangular		\$725.00
ZB2	Trailer Package		\$395.00
ZLQ	WT Fleet Convenience Package		\$695.00
—	Battery, heavy-duty 720 cold-cranking amps/80 Amp-hr, maintenance-free	Inc.	

SUBTOTAL	\$45,100.00
Adjustments Total	\$0.00
Destination Charge	\$1,595.00
TOTAL PRICE	\$46,695.00

FUEL ECONOMY

Est City: 15 MPG

DEALER GM SOFT TONNEAU COVER 600
INSTALLED
MSRP - 47295

This document contains information considered Confidential between GM and its Clients uniquely. The information provided is not intended for public disclosure. Prices, specifications, and availability are subject to change without notice, and do not include certain fees, taxes and charges that may be required by law or vary by manufacturer or region. Performance figures are guidelines only, and actual performance may vary. Photos may not represent actual vehicles or exact configurations. Content based on report preparer's input is subject to the accuracy of the input provided.
Data Version: 8480. Data Updated: Jun 2, 2019 9:30:00 PM PDT.



~~2019~~ 2020

SILVERADO SPECIAL SERVICE



GENERAL MOTORS FLEET

2019 2020



About This Publication

This catalog is not updated during the model year and should not be used for ordering purposes. It is intended as a source of basic information. All illustrations and specifications in this literature are based on the latest product information available at the time of publication. General Motors reserves the right to make changes at any time without notice. For further details, consult your local dealer.

Care must be taken during customer installation of equipment and wiring to ensure that all holes drilled in the body are corrosion protected, properly sealed and that vehicle wiring harnesses, piping or other components have not been displaced or damaged. Wiring connection or splice changes are to be removed before the vehicle is returned to civilian use. Aftermarket equipment installers must be mindful of applicable Federal Motor Vehicle Safety Standards. This information can be obtained directly from the National Highway Traffic Safety Administration.

Adding non-dealer accessories or making modifications to the vehicle can affect vehicle performance, aerodynamics, and overall top speed.

These vehicles are equipped with an airbag system. The airbag system in your police vehicle includes frontal driver and front outboard passenger airbags, front seat back side impact airbags, roof rail mounted head-curtain airbags and if available, front knee airbags or knee bolsters. Customer installed equipment such as security barriers behind the front seats should not be mounted so that the barrier ends are within the side airbag deployment zones. The sensors and other components for the airbag system must not be relocated to accommodate the installation of customer furnished equipment; please refer to the service manual for sensor and other component locations. For information concerning instrument panel top pad mounted equipment and airbag system deployment zones, see the airbag information section in this catalog and the vehicle owners manual.

A note about vehicle alterations by independent suppliers: This catalog shows pictures of vehicles that have been altered or upfitted with equipment or components supplied to Chevrolet or its dealers by independent suppliers. Chevrolet is not responsible for the safety or quality of design features, materials or workmanship of any alterations by a supplier.

Copyright 2018 General Motors. All rights reserved. Chevrolet and the Chevrolet Emblem are registered trademarks of General Motors LLC.

INDEX

- **UPDATES FOR 2019 SILVERADO SPECIAL SERVICE 5W4 CREW CAB**
- **STANDARD FEATURES**
- **POWERTRAIN & EMISSIONS**
- **COLORS & INTERIOR TRIM**
- **OPTIONAL EQUIPMENT**
- **SPECIFICATIONS**
- **ILLUSTRATION HIGHLIGHTS**
- **GENERAL MOTORS FLEET OnStar®, SERVICEPLANS AND GM COMMERCIAL LINK PLANS**
- **WIRING DIAGRAMS**
- **AIRBAG DIMENSIONS**
- **AIRBAGS FAQ**
- **STABILITRAK**
- **MAINTENANCE AND WARRANTY**

UPDATES

All new from the ground up

INTERIOR

- Cabin offers more rear leg room, more storage space and enhanced climate control
- Standard 40/20/40 front seating (center seat is bolted in)
- Chevrolet infotainment system with 7" touch-screen display
- Brake life monitor
- Available Integrated trailer brake controller (JL1)

EXTERIOR

- Front fender air curtains improve efficiency
- Fixed steel body components and aluminum swing panels (doors, hood, tailgate)
- Roll-formed, high-strength-steel bed floor
- Durabed includes 120v outlet in rear and 12 fixed tie downs (10 additional cubic feet of bed space)
- EZ-Lift & Lower tailgate
- CornerStep bumper features larger footwells than before
- SSV available in 1WT trim level only
- Trailing mirrors no longer available
- (S3U) Fog Lamps - front mounted LED

CHASSIS

- Fully boxed steel frame has 10 percent greater torsional rigidity
- Forged-aluminum upper control arms provide better wheel alignment than previous design
- Redesigned live-axle rear suspension

2019 SILVERADO SPECIAL SERVICE 5W4

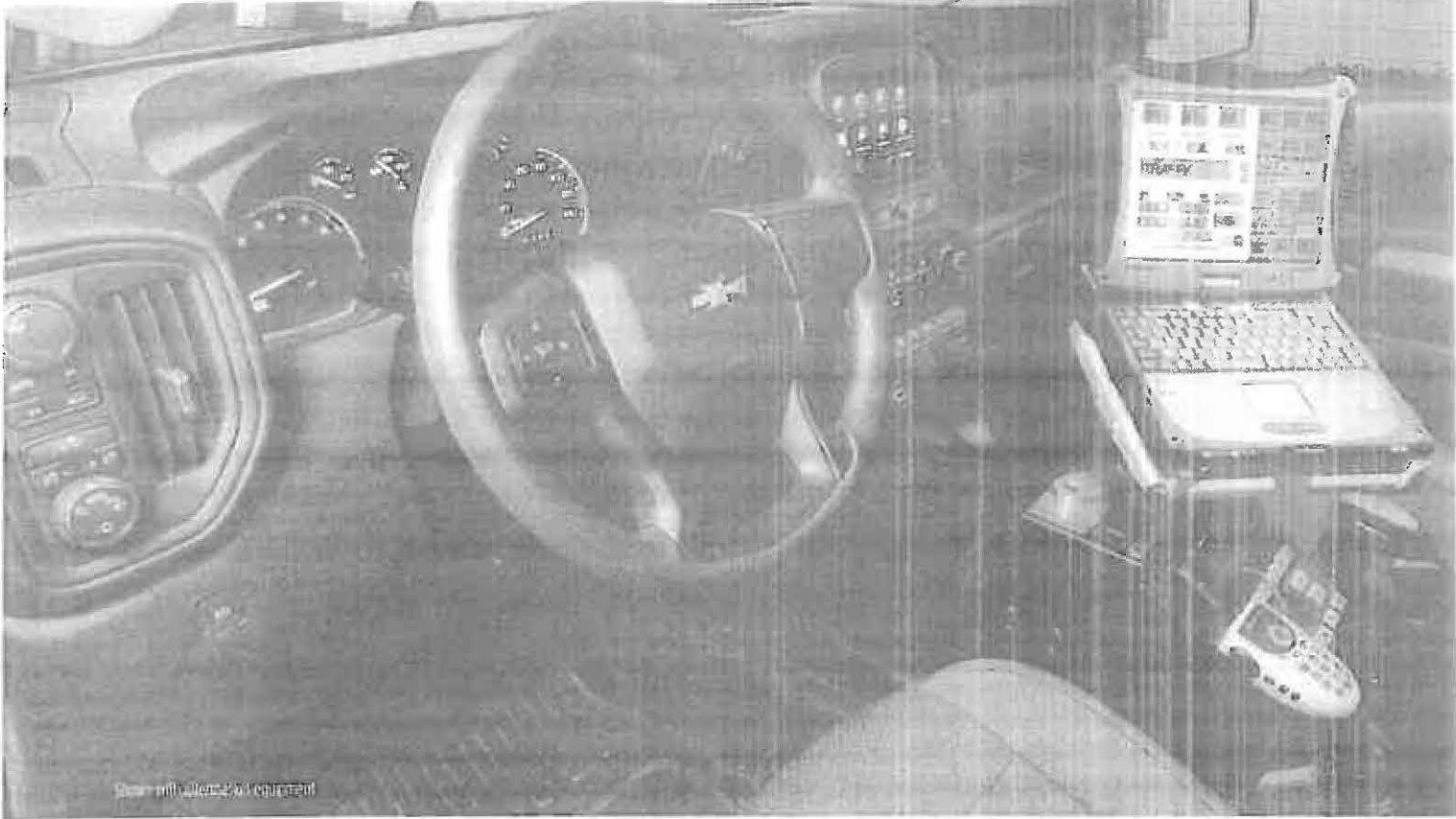

Shown with optional equipment



Standard 120-volt power outlet in bed



Standard 7" touchscreen radio

2019 SILVERADO 1500 SPECIAL SERVICE 5W4 CREW CAB

NOTE: This vehicle is not designed nor intended for use in high speed emergency vehicle operations. Special Service Package includes: 3.5L EcoTec3 V6 Engine, Heavy duty air conditioning, 120-volt, 400-watt power outlet, 120-volt, bidirectional power outlet, calibration that disables vehicle key panic button and exterior lights when at factory default. Special Service Mode Calibration disables interior and exterior lighting when activated. Also includes Fleet Convenience Package. SSV is only available as 1WT on the following models:

2 Wheel Drive (C010) F3 Short Box (6 feet 6 inches)
4 Wheel Drive (C005) F3 Short Box (6 feet 6 inches)

2 Wheel Drive (C010) F3 Standard Box (6 feet 6 inches)
4 Wheel Drive (C005) F3 Standard Box (6 feet 6 inches)

INTERIOR FEATURES MODEL 1WT WITH OPTION 5W4

AIR CONDITIONING	Single-zone with rear Heating/Cooling air vents.
ASSIST HANDLES	Front A-pillar mounted for driver and passenger, rear B-pillar mounted.
AUDIO SYSTEM FEATURES ¹	Chevrolet Infotainment System ³ with 7" diagonal color touch-screen, AM/FM stereo with seek-and-scan and digital clock, includes Bluetooth streaming audio for music and select phones; featuring Android Auto and Apple CarPlay capability for compatible phones. Includes 6 speaker system.
BLUETOOTH ²	Personal cell phone connectivity to vehicle Infotainment System.
COMPASS	Located in instrument cluster. Requires UE1 OnStar
CONVENIENCE PACKAGE	Includes, Remote Keyless Entry, EZ Lift power lock and release tailgate, cruise control and power mirrors. When ordered with (PQA) WT Safety Package, (DLF) power mirrors include (UKC) Lane Change Alert with Side Blind Zone Alert and (DP6) High-gloss mirror caps.
DOOR LOCKS	Power
DRIVER INFO. CENTER	3.5 inch diagonal monochromatic display, provides warning messages and basic vehicle information
FLOOR COVERING	Rubberized Vinyl (Floor mats not included)
INSTRUMENTATION CLUSTER	6-gauge cluster featuring speedometer, fuel level, engine temperature, tachometer, voltage and oil pressure
MIRROR	Inside rearview manual tilt
POWER OUTLET	Located on Instrument panel and Bed Mounted 120-volt (400 watt).
REAR VISION CAMERA	Dynamic guiding lines allows the driver to view objects directly behind the vehicle via the available screen in the center stack.
RESTRAINT SYSTEM ³	Seat belts at all designated seating positions with driver and front outboard passenger pretensioners. Airbags: Dual-stage frontal airbags for driver and front outboard passenger; includes front outboard Passenger Sensing System. Driver and front outboard passenger knee bolsters. Seat-mounted side-impact airbags for driver and front outboard passenger; Head Curtain airbags for front and rear outboard seating positions. NOTE: Nine inch seat belt extenders are available (part number 19259268) through our dealers at no charge.
SEAT, FRONT	40/20/40 Split Bench with Vinyl trim. Driver and front passenger seat adjuster are 4-way manual (for cloth trim and power seat availability see seat availability page).
SEAT, REAR	60/40 folding bench (folds up), 3-passenger (includes child seat top tether anchor). Includes Rear seat reminder.
SURVEILLANCE MODE	Calibration to disable interior & exterior automatic lighting. Feature is activated by adding wire connection to the BCM by customer/upfitter.
STEERING COLUMN	Tilt-Wheel, manual with wheel locking security feature
TEEN DRIVER MODE	Configurable feature that lets you activate configurable features that activates vehicle settings associated with a key fob, to encourage safe driving behavior. It can limit certain vehicle features, and it prevents certain safety systems from being turned off. An in-vehicle report card gives you information on driving habits and helps you to continue to coach your new driver.
TEMPERATURE DISPLAY	Exterior temperature display located in radio display
USB PORT	Located on instrument panel
WINDOWS	Power front, drivers express up/down. Front passenger express down. Rear power express down.

EXTERIOR FEATURES - MODEL 1WT WITH OPTION 5W4

BUMPER FRONT	Black (semi-gloss).
BUMPER REAR	Black (semi-gloss) with corner step.
CARGO TIE DOWN	12 fixed, Rated at 500 pounds per corner.
CAPLESS FUEL FILL	The vehicle has a capless refueling system and does not have a fuel cap. The filling nozzle must be fully inserted and latched prior to starting fuel flow. NOTE: Overfilling the fuel tank by more than three clicks of a standard fill nozzle may cause vehicle performance issue, including engine stalling and damage to the fuel system, fuel spills, potential fuel fires
DOOR HANDLES	Black
GLASS	Solar absorbing, tinted.

1. Functionality varies by model. Full functionality requires compatible Bluetooth and smartphone, and USB connectivity for some devices

2. Go to myChevrolet.com/learnAbout/bluetooth to find out which phones are compatible with the vehicle

3. Always use seat belts and child restraints. Children are safer when properly secured in a rear seat in the appropriate child restraint. See the Owner's Manual for more information

2019 SILVERADO 1500 SPECIAL SERVICE 5W4 CREW CAB

GRILLS	Black bars with mesh inserts
HEADLAMPS	Halogen reflector with halogen Daytime Running Lamps and Automatic exterior lamp control. Altering headlamp assembly is not-Recommended. General Motors is not responsible for the effects of any modifications
LAMPS	Cargo area, cab mounted integrated with center high mount stop lamp, with switch on center switch bank
MIRRORS, OUTSIDE	Black, Manual
POWER OUTLET	Bed mounted 120-volt (400 watt)
PICKUP BED	Built from high-strength roll-formed steel for durability with 12 fixed corner tie downs and 110v outlet
RECOVERY HOOKS	Front, frame-mounted, Black included with 4WD models or included and only available on 2WD models with (PQA) WT Safety Package
TAILGATE	Gate function manual, no lift assist Locking, utilizes same key as Ignition and door. Includes Tailgate and bed rail protection cap.
TAILLAMPS	Incandescent tail, stop and reverse lights
TIRES	255/70R17 all-season, blackwall (includes P255/70R17 All-season blackwall spare tire)
TIRE PRESSURE MONITOR WITH TIRE FILL ALERT	Tire Pressure Monitoring System. Standard spare wheel not equipped with TPM sensor. Includes Tire Fill Alert in addition to the DIC warning when a tire has low pressure. This feature provides audible and visual indication when air is being added to the low tire to aid in achieving optimal tire pressure.
TIRE SPARE CATCHER	Keyed cylinder lock utilizes same key as ignition and door
WHEELS	17 inch x 8 inch Ultra Silver Painted Steel, includes spare
CHASSIS FEATURES - MODEL 1WT WITH OPTION 5W4	
AIR FILTER	High capacity
ALTERNATOR	220 amp Charging System with Idle Boost increases alternator output at idle with increased electrical load. See Specifications page for Alternator Output Chart.
BATTERY	Heavy-duty 720 cold-cranking amps/80 Amp-hr, maintenance-free with rundown protection and retained accessory power
BRAKES	4-wheel disc with DURALIFE rotors, 4-wheel antilock
BRAKE WEAR	Brake wear indicator
BRAKE PAD LIFE DISPLAY	Displays an estimate of the remaining life of the front and rear brake pads. Messages will display based on brake pad wear and the state of the system. Reset the Brake Pad Life display after replacing the brake pads. See Brake Pad Life
BRAKE PAD LIFE SYSTEM	Tells when to Change Brake Pads. Brake pad life is displayed in the Driver Information Center (DIC), along with a percentage for each axle. When the system has determined that the brake pads need to be replaced a message will display which may include mileage remaining. Brake pads should always be replaced as complete axle sets.
ENGINE	5.3L EcoTec3 V8 with Active Fuel Management, Direct Injection and Variable Valve Timing, includes aluminum block construction (355 hp [265 kW] @ 5600 rpm, 383 lb-ft of torque [518 Nm] @ 4100 rpm; more than 300 lb-ft of torque from 2000 to 5600 rpm)
FRAME	Fully-boxed, hydroformed front section
FUEL TANK	Approximately 26 gallon (98 liter)
OIL COOLING	External engine oil cooler and auxiliary transmission oil cooler
RADIO SUPPRESSION	The Silverado vehicle systems are designed to prevent unwanted emissions and to minimize susceptibility and maximize immunity to external emissions (Electromagnetic (EMI) or Radio Frequency (RFI) Interference). Most emergency vehicle communications equipment operating at frequencies in the VHF Band (30-300 MHz) and up to frequencies in the UHF Band (300 MHz-3GHz) will function as intended without enhanced noise suppression.
REAR AXLE	3.42
STABILITRAK	Stability control system with Proactive Roll Avoidance and traction control Includes electronic trailer sway control and hill start assist. For description see Stability Control and Traction Control section
STEERING	Electric Power Steering (EPS) assist, rack-and-pinion
SUSPENSION, FRONT	Independent, coil over shock, includes 35mm twin tube shock absorbers
SUSPENSION, REAR	2-Stage multi-leaf springs, semi-elliptic
TRANSFER CASE	Single speed, electronic Autotrac with rotary dial control.
TRANSMISSION	6-speed automatic electronically controlled with overdrive and tow/haul mode. Includes Cruise Grade Braking and Powertrain Grade Braking
WARRANTY	See Maintenance and Warranty section for description

4. WARNING: The camera(s) do not display children, pedestrians, bicyclists, crossing trac, animals, or any other object outside of the cameras' field of view, below the bumper, or under the vehicle. Shown distances may be different from actual distances. Do not drive or park the vehicle using only these camera(s). Always check behind and around

2019 SILVERADO 1500 SPECIAL SERVICE SW4 CREW CAB

FRONT SEATS AND INTERIOR TRIM

STANDARD (A52) - 40/20/40 SPLIT-BENCH IN VINYL TRIM, 3-passenger, driver and front passenger manual recline with outboard head restraints, fold-down armrest with storage and fixed lumbar. Driver and front passenger seat adjuster are 4-way manual. Cloth trim and (A2X) 10-way power driver seat including lumbar is available and requires (ZLQ) WT Fleet Convenience Package.

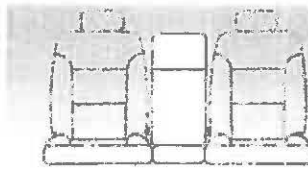
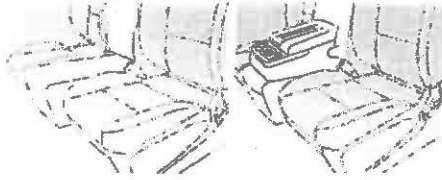

Seat Code	Seat Trim	Color	Color Code
A52	Vinyl Cloth	Jet Black Jet Blue	H2G H2J

REAR SEATS AND INTERIOR TRIM

STANDARD - A68 VINYL REAR SEAT Vinyl rear bench 60/40 split-folding seat.

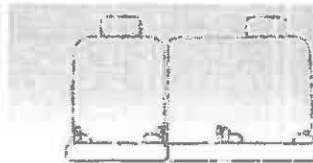

Seat Code	Seat Trim	Color	Color Code
A68	Vinyl Cloth	Jet Black Jet Blue	H2G H2J

AVAILABLE INTERIOR COLOR Actual colors may vary

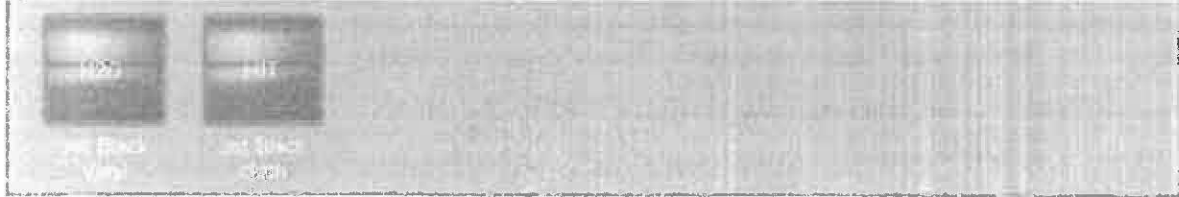

AVAILABLE EXTERIOR COLORS Actual colors may vary



**2019 SILVERADO 1500
SPECIAL SERVICE SW4 CREW CAB**

SEO PAINT AVAILABLE

COLOR DESCRIPTION	SEO CODE	WA#
Woodland Green	9V5	9015
Doeskin Tan	NONE	9403
Wheatland Yellow (86U)	9W3	253A
Tangier Orange	9W4	9417
Unripened Green Metallic	NONE	175X
Indigo Blue	NONE	979Z
Lt. Autumnwood Metallic	NONE	228A
Pewter	NONE	382E
Dark Toreador Red	NONE	334D
Orange	NONE	WA-770H
Orange	NONE	WA-9419
Yellow	NONE	WA-5248
Yellow	NONE	WA-5445
Yellow	NONE	WA-5456
Yellow	NONE	WA-9414
Blue	NONE	WA-454N
Blue	NONE	WA-54C
Arrival Blue Metallic	NONE	WA-815I

NOTE:

- Actual color may vary
- GM will require 5 orders before sending to the plant
- May require extended lead time.

**2019 SILVERADO 1500
SPECIAL SERVICE SW4 CREW CAB**

POWERTRAIN

ENGINE				TRANSMISSION		AXLE	
OPTION CODE	TYPE	DISPLACEMENT LITERS/CU. IN.	FUEL SYSTEM	OPTION CODE	TYPE	OPTION CODE	RATIO
L82	V8	5.3/325	Direct Injection	MYC	6-speed auto. with OD	GU6	3.42

EMISSIONS - (SELECT OR SPECIFIED)

FE9	Emissions, Federal requirements
NE1	Emissions, Connecticut, Delaware, Maine, Maryland, Massachusetts, New Jersey, New York, Oregon, Pennsylvania, Rhode Island, Vermont and Washington state requirements
NB8	Emissions override, California (allows a dealer in states that require California emissions - California, Connecticut, Delaware, Maryland, Massachusetts, New Jersey, New York, Oregon, Pennsylvania, Rhode Island or Washington - to order Federal emissions for a vehicle that will be registered in a state that has Federal emission requirements). Do not use for vehicles that will be registered in California, Connecticut, Delaware, Maryland, Massachusetts, New Jersey, New York, Oregon, Pennsylvania, Rhode Island or Washington. Requires (FE9) Federal emissions requirements. Not available in Maine or Vermont.
NB9	Emissions override, state-specific (for dealers ordering vehicles in (YF5) or (NE1) emission states - California, Connecticut, Delaware, Maine, Maryland, Massachusetts, New Jersey, New York, Oregon, Pennsylvania, Rhode Island, Vermont and Washington). Allows a California dealer (YF5 emissions) to order (NE1) emissions with (NB9) emissions override code for registration in (NE1) states; or, a Connecticut, Delaware, Maine, Maryland, Massachusetts, New Jersey, New York, Oregon, Pennsylvania, Rhode Island, Vermont and Washington dealer (NE1 emissions) to order (YF5) emissions with (NB9) emissions override code for registration in California.
NC7	Emissions override, Federal (for vehicles ordered by dealers in Federal emission states with (YF5) or (NE1) emissions - Not required for vehicles being shipped to California, Connecticut, Delaware, Maine, Maryland, Massachusetts, New Jersey, New York, Oregon, Pennsylvania, Rhode Island, Vermont or Washington). Requires (YF5) California state emissions requirements or (NE1) Connecticut, Delaware, Maine, Maryland, Massachusetts, New Jersey, New York, Oregon, Pennsylvania, Rhode Island, Vermont or Washington state emissions requirements.
YF5	Emissions, California state requirements

SPEEDOMETER CERTIFICATION CALIBRATION

Specifications at ambient temperature of -10 to 120 degrees F (-23 to 49 Celsius). Inaccuracies due to vehicle speed sensing are included

ACTUAL VEHICLE SPEED	INDICATED SPEED
0 TO 120 MPH	+/- 2 MPH
0 TO 193 KPH	+/- 3 KPH

The speedometer calibration is for the 2019 Silverado SW4 Special Service with the 5.3L engine, automatic transmission with a 3.42 axle and 255/70R17 tires

OPTIONAL EQUIPMENT

INTERIOR

- VW4 4G LTE WI-FI¹ HOTSPOT¹** - Can connect up to 7 devices. Includes 4G LTE data trial for 1 month or 3GB (whichever comes first). Available Wi-Fi requires compatible mobile device, active OnStar service and data plan. Data plans provided by AT&T. Visit www.gmfleet.com/technology/connected-vehicle.html for details and system limitations.
- UTC ALARM, HORN CONTENT THEFT DETERRENT, DISABLED** - Calibration disables the horn for the theft deterrent alarm. Requires CC10743 and CK10743 model and (5W4) Special Service Vehicle
- R1A ALL WEATHER FLOOR LINER** - 1st and 2nd rows (Includes Chevrolet Bowtie logo). Requires (B30) color-keyed carpeting.
- S31 CALIBRATION, KEYLESS REMOTE PANIC BUTTON EXTERIOR LIGHT/HORN DISABLE** - Included with CC10743 and CK10743 model and (5W4) Special Service Vehicle
- S32 CALIBRATION, SURVEILLANCE MODE INTERIOR LIGHTING** - Calibration to disable interior automatic lighting. Feature is activated by adding wire connection to the BCM by customer/upfitter. Requires CC10743 and CK10743 model and (5W4) Special Service Vehicle
- K34 CRUISE CONTROL** - Electronic with set and resume speed, steering wheel-mounted. Included with (ZLQ) WT Fleet Convenience Package
- C49 DEFOGGER, REAR WINDOW** - Electric
- HT0 FLOOR COVERING** - Color-keyed carpeting. Includes front and rear vinyl floor mats
- PCV LOCK CONTROL REAR DOOR, AUTO DOOR LOCKS DISABLE** - Calibration disables auto door locks and is activated through radio or DIC settings. Requires CC10743 and CK10743 model and (5W4) Special Service Vehicle and Government order.
- UF1 OnStarSM** - Fleet orders receive a 3-month trial of Fleets Connection Services and 3 months of Fleet Safety & Security plan coverage. Connected services include navigation services and remote access plan and 1 month 3 GB of 4G LTE data (whichever comes first) from vehicle delivery date. Data plans offered by AT&T. Certain service require working electrical system, cell service, GPS signal. Onstar links to emergency services. See www.gmfleet.com/technology/connected-vehicle.html for details and limitations
- UD7 REAR PARK ASSIST** - Ultrasonic Requires (R13) WT Appearance Package, (ZB2) Trailing Package, (JL1) trailer brake controller, (ZLQ) WT Fleet Convenience Package and (K14) power outlet.
- V61 REAR UNDERSEAT STORAGE** - Composite storage bin (see optional equipment section for illustration)
- 6T5 SEATS** - Front cloth and second row vinyl.
- A2X SEAT ADJUSTER** - Driver 10-way power seat including lumbar. Requires (ZLQ) WT Fleet Convenience Package, (K14) 120-volt power outlet and (KCS) 120-volt bed-mounted power outlet
- SLS THEFT DETERRENT SYSTEM FLEET IMMOBILIZER** - In the absence of master key, reduces roadside key relearn process to (3) two-minute cycles in place of the standard (3) ten-minute cycles. This option will also allow for only one learned key to be needed when adding additional keys instead of 2 learned keys. Requires a Fleet or Government type order.
- ZLQ WT FLEET CONVENIENCE PACKAGE** - Includes (AQQ) Remote Keyless Entry, (QT5) EZ Lift power lock and release tailgate, (K34) cruise control, (DLF) power mirrors; Regular Cab models also include (AXG) power windows, express up/down driver, (AED) power windows, express down passenger and (AU3) power door locks. When ordered with (PQA) WT Safety Package, (DLF) power mirrors include (UKC) Lane Change Alert with Side Blind Zone Alert and (DP6) high-gloss mirror caps.
- BDA WT SAFETY PACKAGE** - Includes (UD5) Front and Rear Park Assist, (UKC) Lane Change Alert with Side Blind Zone Alert, (UFG) Rear Cross Traffic Alert, (V46) Chrome front bumper, (VJH) Chrome rear bumper and (DP6) high gloss Black mirror caps. Includes Perimeter Lighting. Requires (PCV) WT Convenience Package or (ZLQ) WT Fleet Convenience Package and (K14) 120-volt power outlet. 2WD models include (V76) recovery hooks. Not available with (UD7) Rear Park Assist.

EXTERIOR

- V20 ASSIST STEP** - Black work step, Included with (PDW) Assist Step and Tonneau Value Package. Not available with any other assist steps.
- PDR ASSIST STEP AND TONNEAU PACKAGE** - Includes (VOZ) Tri-fold hard tonneau cover, your choice of either (RVQ) 6" Black rectangular assist steps, (RVS) 4" Black round assist steps, (VXH) 6" chrome rectangular chrome round assist steps. Not available with (PDW) Assist Step and Tonneau Value Package.
- PDW ASSIST STEP AND TONNEAU VALUE PACKAGE** - Includes (VGO) Black work step, (63B) Tri-fold soft tonneau cover. Requires Crew Cab or Double Cab model. Not available with (PDR) Assist Step and Tonneau Package or any other assist steps or tonneau covers.
- V1X ASSIST STEPS** - Chromed tubular, 6" rectangular. Not available with any other assist steps.
- VX1 ASSIST STEPS** - Chromed round 4". Not available with any other assist steps
- 6V0 ASSIST STEPS** - Black 6" tubular rectangular. Not available with any other assist steps
- RVS ASSIST STEPS** - Black 4" round. Not available with any other assist steps
- CON BEDLINER, CHEVYTEC SPRAY-ON** - Black with Chevrolet logo (does not include spray-on liner on tailgate due to Black composite inner panel). Not available with (ZW9) pickup bed delete. Not available with any Ship Thru EXCEPT (VCO), (VDT), (VYC) or (VYS).
- 6V9 BEDSIDE STORAGE BOXES.** Locking over the wheel well hard plastic weatherproof storage (left and right side). See OPTIONAL EQUIPMENT page for picture.
- S30 CALIBRATION, TAILLAMP FLASHER, RED/WHITE** - Calibration flashes white (backup) and red (brake lamps) alternately when actuated. Requires CC10743 or CK10743 model and SW4 Special Service Vehicle.
- V07 CHROME RECOVERY HOOKS** - Requires 2WD model. Deletes and not available with (V76) Black recovery hooks
- 6C1 DAYTIME RUNNING LAMPS DELETE** - Daytime Running Lamps and automatic headlamp control delete, deletes standard Daytime Running Lamps and automatic headlamp control features from the vehicle for police stealth surveillance.
- 8M4 DECAL AND NAME PLATE DELETE** - Tailgate. Deletes all nameplates and decals on the pickup box tailgate. Not available with SEO (8F2) ornamentation delete.
- 6T1 DECAL DELETE** - Pickup box Deletes the "4x4" decal from the side of the pickup box. Requires 4WD models only. Not available with SEO (8F2) ornamentation delete
- 6T1 FOG LAMPS** - Front mounted; LED. Requires Fleet or Government order type.

1. Service varies with conditions and location. Requires active OnStar service and paid AT&T data plan. Visit www.gmfleet.com/technology/connected-vehicle.html for details and limitations.

2019 SILVERADO 1500 SPECIAL SERVICE 5W4 CREW CAB

- AWD GLASS - Deep tinted**
- KE7 KEY SINGLE - Complete vehicle fleet.** Provides a single key with a specific code that is common to the door locks and ignition of all the vehicles in the vehicle fleet. Key code is an alternate to SEO 6E8 complete vehicle fleet common key.
- KE8 KEY SINGLE - Complete vehicle fleet.** Provides a single key with a specific code that is common to the door locks and ignition of all the vehicles in the fleet. Key code is an alternate to SEO 6E2.
- 3H1 KEY EQUIPMENT - Two additional keys for single key system.** Provides two additional spare keys for a total of (4). (Keys will be cut but not programmed) Programming of keys is at customer's expense. Programming keys is not a warranty claim.
- UF2 LED CARGO AREA LIGHTING - Located in pickup bed,** activated with switch on center switch bank or key fob
- VJ3 LICENSE PLATE KIT - Front (will be shipped to orders with ship-to states that require front license plate)**
- DP6 MIRROR CAPS, PAINTED - Body-color.** High gloss Black included and only available with (PQA) WT Safety Package.
- MF MIRRORS, OUTSIDE - Heated power-adjustable (included and only available with (ZLQ) WT Fleet Convenience Package.** When (PQA) WT Safety Package is ordered. Includes (DP6) Mirror caps, body-color. High gloss Black included and only available with (PQA) WT Safety Package.
- 6F2 ORNAMENTATION, DELETE - Deletes decals and nameplates on truck exterior**
- 6V5 PAINT - Solid, Woodland Green** All normally body colored non-sheet metal parts will be Black May require extended lead time. Door handles and mirrors will be grain Black Deletes standard/packaged body side moldings. Requires (TGK) Special Paint and (01U) Special Paint.
- 6W7 PAINT - Solid, Wheatland Yellow.** All normally body colored non-sheet metal parts will be Black May require extended lead time. Door handles and mirrors will be grain Black Deletes standard/packaged body side moldings. Requires (TGK) Special Paint and (01U) Special Paint.
- 6W4 PAINT - Solid, Tangerine Orange.** All normally body colored non-sheet metal parts will be Black May require extended lead time. Door handles and mirrors will be grain Black Deletes standard/packaged body side moldings. Requires (TGK) Special Paint and (01U) Special Paint.
- 5FW REAR BACKUP ALARM CALIBRATION - This calibration will allow installation of an aftermarket backup alarm.** Not available with SEO (8S3) backup alarm.
- V76 RECOVERY HOOKS - Front, frame-mounted.** Black Standard with 4WD models. Available with 2WD models.
- 6D1 SPECIAL EXTERIOR SPECIAL EXTERIOR COLOR - All normally body colored non-sheet metal parts will be black** including front fender extensions, cab spoiler on Double & Crew cabs and LT trim door handles. May require extended lead time.
- VO4C SPLASH GUARDS, MOLDED - Black (see optional equipment section for illustration)**
- 5AF TIRE CARRIER LOCK** Keyed cylinder lock utilizes same key as ignition and door
- 6HM TIRE, SPARE - LT265/70R17 all-terrain, blackwall 1 -** When equipped with (E63) Durabed, included and only available with (RC5) LT265/70R17C all-terrain, blackwall tires. Available with and requires (RC5) LT265/70R17C all-terrain, blackwall tires.
- XCG TIRE, SPARE - 265/70R17SL all-season, blackwall.** Requires (QDV) 265/70R17 all-terrain blackwall tires or all 18" wheels and tires
- QDV TIRES - 265/70R17 all-terrain, blackwall**
- HC3 TIRES - LT265/70R17C all-terrain, blackwall.** Includes spare tire
- 61D TIRES, LT275/65R18C MT - Goodyear Wrangler DuraTrac,** Blackwall. Requires (Z71) Off-Road Package and (PZX) 18" Bright Silver painted aluminum wheels
- 646 TIRE, SPARE 265/70R17 - Replaces the standard blackwall all-season spare tire with all-terrain tread spare matching road tires.** Requires 4WD model and (QDV) 265/70R17 all-terrain, blackwall tires. Not available with (5Z4) spare wheel, carrier and lock delete
- V01 TONNEAU COVER - Hard tri-folding with vinyl cover,** Requires (UF2) LED Cargo Box Lighting
- 655 TRI-FOLD SOFT TONNEAU COVER - Included with (PDW) Assist Step and Tonneau Value Package,** LPO. Not available with any other tonneau cover.
- VO2 TRI-FOLD HARD TONNEAU COVER - Included with (PDR) Assist Step and Tonneau Package.** Not available with any other tonneau cover.
- 9ZY WHEELS - 18" x 6.5" (45.7 cm x 21.6 cm) Bright silver painted aluminum.** Requires (Z71) Off-Road Package and (R30) 265/70R18 tires.
- 5FE WHEEL LOCKS - Set of 4**
- 6Z4 WHEEL, SPARE - Carrier and lock delete.** Deletes the base spare wheel, carrier and lock. Does not delete jack or tools. Requires SEO (9L3) spare tire delete. Not available with (RC3). Tires, 265/70R17 all-terrain, blackwall.
- 00A WHEEL, SPARE - Upgrade.** Replaces Black standard spare wheel and upgrades to a matching Silver steel road wheel. Includes tire pressure monitoring sensor. Requires (RD6) painted steel wheels. Not available with SEO. (5Z4) spare wheel, carrier and lock delete.
- 611 WT APPEARANCE PACKAGE - Includes (V46) Chrome front bumper,** (VJH) Chrome rear bumper and (Q5U) 17" Bright Silver painted aluminum wheels. Not available with (Z71) Off-Road Package.

CHASSIS

- K47 AIR FILTER, HIGH CAPACITY - Included in (5W4) Special Service Package.**
- K05 ENGINE BLOCK HEATER**
- FH5 E85 FLEX FUEL CAPABLE - Can run on unleaded or up to 85% ethanol.** Requires (L82) 5.3L EcoTec3 V8 engine
- Q07 FLEET FREE MAINTENANCE CREDIT - This option code provides a credit in lieu of the free oil changes, tire rotations and inspections for one maintenance service during 1st year of ownership.** The invoice will detail the applicable credit. The customer will be responsible for all oil change, tire rotations and inspections costs for this vehicle. Requires one of the following Fleet or Government order types: FBC, FBN, FCA, FCN, FLS, FNR, FRC or FGO. Not available with FDR order types.
- HC2 GOVERNOR, ELECTRONIC SPEED SENSOR SET TO 65 MPH - Provides electronic software to limit maximum road speed to 65-MPH.** Cruise control limited to 60 MPH.
- 911 GOVERNOR, ELECTRONIC SPEED SENSOR SET TO 70 MPH - Provides electronic software to limit maximum road speed to 70-MPH.** Cruise control limited to 65 MPH
- 907 GOVERNOR, ELECTRONIC SPEED SET TO 75 MPH - Provides electronic software to limit maximum road speed to 75-MPH.** Cruise control limited to 70 MPH.

**2019 SILVERADO 1500
SPECIAL SERVICE SW4 CREW CAB**

- Z71 OFF-ROAD PACKAGE** - Off-Road Package, Includes (Z71) Off-Road suspension, (JHD) Hill Descent Control, (NZZ) skid plates, (K47) heavy-duty air cleaner and Z71 hard badge. Requires 4WD model, (Z82) Trailing Package and AT or M1 tires. Includes (G80) locking differential and (NQH) 2-speed transfer case. Not available with (R13) WT Appearance Package.
- R69 REAR DIFFERENTIAL** - Heavy-duty locking
- JL1 TRAILER BRAKE CONTROLLER** - Integrated (requires Z82 trailing package)
- Z82 TRAILERING PACKAGE** - Includes trailer hitch, 7-pin and 4-pin connectors and (CTT) Hitch Guidance
- H94 TRANSFER CASE, TWO-SPEED** - Electronic Autotrac with rotary dial control (4WD models only) Included and only available with (Z71) Off-Road Package.
- Z82 TRAILERING PACKAGE** - Includes trailer hitch, 7-pin and 4-pin connectors and (CTT) Hitch Guidance with (L82) 5.3L EcoTec3 V8 engine requires (G90) locking differential
- NZZ SKID PLATES** - Included with (BAQ) Work Truck Package, (Z71) Off-Road Package or (VYU) Snow Plow Prep Package.
- VKZ SHIP THRU** - Produced in Silao Assembly and shipped to Kerr Industries. Returned to Arlington Assembly for shipping to final destination (Dealer Invoice = \$510.00).
- BAQ WORK TRUCK PACKAGE** - Includes (NZZ) skid plates and (K47) heavy-duty air cleaner. Requires 4WD model, (QDV) 265/70R17 black all-terrain tires or (RC5) LT265/70R17C all-terrain tires. Not available with (Z71) Z71 Off-Road Package or (VYU) Snow Plow Prep Package

NOTE: See dealer for additional dealer installed accessories.

2019 SILVERADO 1500 SPECIAL SERVICE 5W4 CREW CAB

FLEET CONNECTED SERVICES AND OnStar PLANS¹

- POJ** **ADDITIONAL 21 MONTHS OF FLEET SAFETY & SECURITY PLAN.** Provides 21 months of Safety and Security Plan coverage in addition to the 3 months of standard coverage that is included in the price of the vehicle. Total Safety & Security Plan service duration is 24 months. Requires (UE1) OnStar. Requires one of the following: Fleet or Government order types: FLS, FNR, FRC, FBC, FGO or FEF. Not available with POK or POL. Not available with a ship-to of Puerto Rico or the Virgin Islands.
- PON** **ADDITIONAL 33 MONTHS OF FLEET REMOTE ACCESS PLAN.** Provides 33 months of Remote Access Plan in addition to the 3 months of standard coverage that is included in the price of the vehicle. Total OnStar Remote Access Plan service duration is 36 months. Requires (UE1) OnStar. Requires one of the following: Fleet or Government order types: FLS, FNR, FRC, FBC, FGO or FEF. Not available with POM or POU. Not available with a ship-to of Puerto Rico or the Virgin Islands.
- POL** **ADDITIONAL 45 MONTHS OF FLEET SAFETY & SECURITY PLAN.** Coverage provides 45 months of Safety and Security in addition to the 3 months of standard coverage that is included in the price of the vehicle. Total Fleet Safety & Security Plan service duration is 48 months. Requires (UE1) OnStar. Requires one of the following: Fleet or Government order types: FLS, FNR, FRC, FBC, FGO or FEF. Not available with POJ or POK. Not available with a ship-to of Puerto Rico or the Virgin Islands.
- POM** **ADDITIONAL 21 MONTHS OF FLEET REMOTE ACCESS PLAN.** Provides 21 months of Remote Access Plan in addition to the 3 months of standard coverage that is included in the price of the vehicle. Total OnStar Remote Access Plan service duration is 24 months. Requires (UE1) OnStar. Requires one of the following: Fleet or Government order types: FLS, FNR, FRC, FBC, FGO or FEF. Not available with PON or POU. Not available with a ship-to of Puerto Rico or the Virgin Islands.
- PON** **ADDITIONAL 33 MONTHS OF FLEET REMOTE ACCESS PLAN.** Provides 33 months of Remote Access Plan in addition to the 3 months of standard coverage that is included in the price of the vehicle. Total OnStar Remote Access Plan service duration is 36 months. Requires (UE1) OnStar. Requires one of the following: Fleet or Government order types: FLS, FNR, FRC, FBC, FGO or FEF. Not available with POM or POU. Not available with a ship-to of Puerto Rico or the Virgin Islands.
- POL** **ADDITIONAL 45 MONTHS OF FLEET REMOTE ACCESS PLAN.** Provides 45 months of Remote Access Plan in addition to the 3 months of standard coverage that is included in the price of the vehicle. Total OnStar Remote Access Plan service duration is 48 months. Requires (UE1) OnStar. Requires one of the following: Fleet or Government order types: FLS, FNR, FRC, FBC, FGO or FEF. Not available with POM or PON. Not available with a ship-to of Puerto Rico or the Virgin Islands.

GM COMMERCIAL LINK

- POJ** **GM COMMERCIAL LINK - 1 YEAR OF SERVICE.** Includes 12 months of GM Commercial Link service. Provides access and reporting for key vehicle information such as speed, location and maintenance through website and mobile application. Eligible customers must sign up for an account at www.gmcommerciallink.com in order take advantage of this 12 month offer. The Commercial Link service is included in the price of the vehicle. Total service duration is 12 months. Non-Transferrable. Non-Refundable. Requires (UE1) OnStar. Requires one of the following: Fleet or Government order types: FLS, FNR, FRC, FBC, FGO or FEF. Not available with (POH) GM Commercial Link - 2 years of Service or (POL) GM Commercial Link - 3 years of Service.
- POH** **GM COMMERCIAL LINK - 2 YEARS OF SERVICE.** Includes 24 months of GM Commercial Link service. Provides access and reporting for key vehicle information such as speed, location and maintenance through website and mobile application. Eligible customers must sign up for an account at www.gmcommerciallink.com in order take advantage of this 24 month offer. The Commercial Link service is included in the price of the vehicle. Total service duration is 24 months. Non-Transferrable. Non-Refundable. Requires (UE1) OnStar. Requires one of the following: Fleet or Government order types: FLS, FNR, FRC, FBC, FGO or FEF. Not available with (POG) GM Commercial Link - 1 year of Service or (POL) GM Commercial Link - 3 years of Service.
- POL** **GM COMMERCIAL LINK - 3 YEARS OF SERVICE.** Includes 36 months of GM Commercial Link service. Provides access and reporting for key vehicle information such as speed, location and maintenance through website and mobile application. Eligible customers must sign up for an account at www.gmcommerciallink.com in order take advantage of this 36 month offer. The Commercial Link service is included in the price of the vehicle. Total service duration is 36 months. Non-Transferrable. Non-Refundable. Requires (UE1) OnStar. Requires one of the following: Fleet or Government order types: FLS, FNR, FRC, FBC, FGO or FEF. Not available with (POG) GM Commercial Link - 1 year of Service or (POH) GM Commercial Link - 2 years of Service.

1. Does not include emergency or security services. Visit www.gmfleet.com/technology/connected-vehicle.html for coverage map, details and system limitations

DIMENSIONS SSV REGULAR BOX

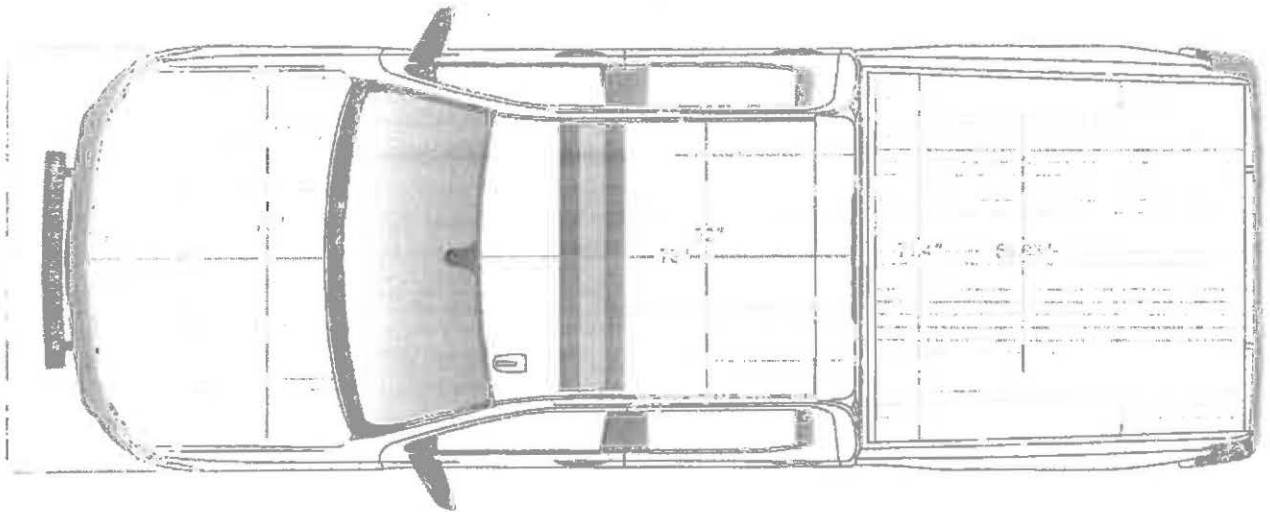
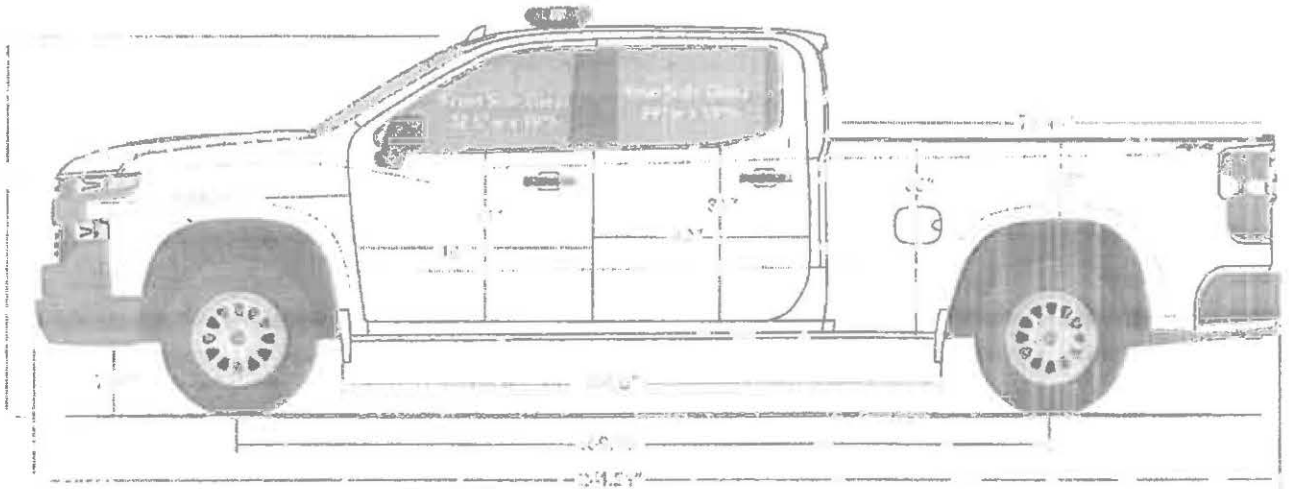

Estimated material sizes to wrap:

- Hood – 72" x 50"
- Front Doors – 50" x 36"
- Rear Doors – 45" x 37"
- Roof – 75" x 54"
- Tailgate – 69" x 26"



DIMENSIONS SSV SHORT BOX

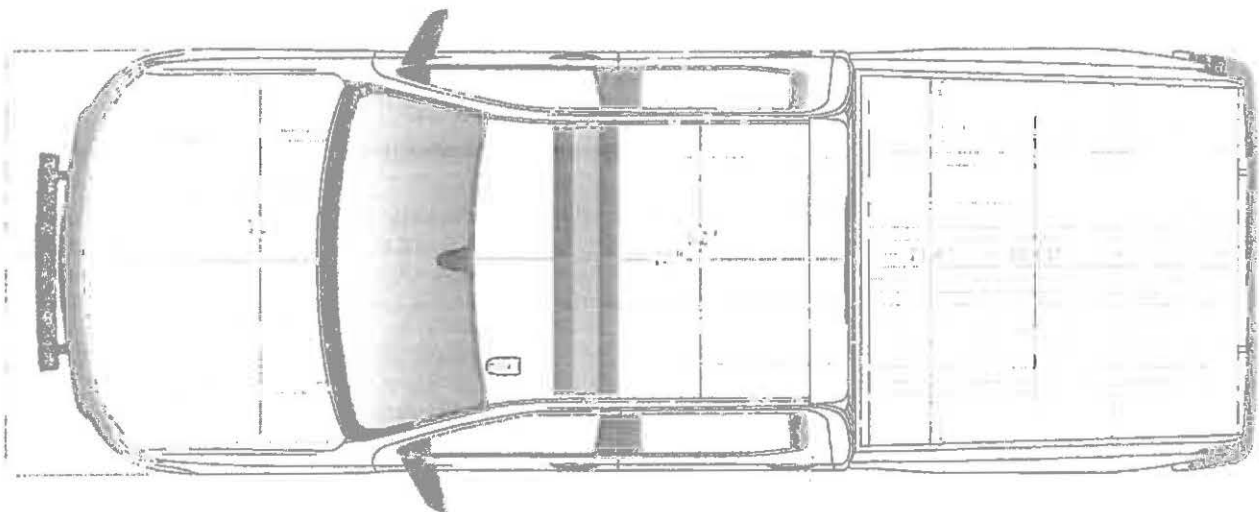
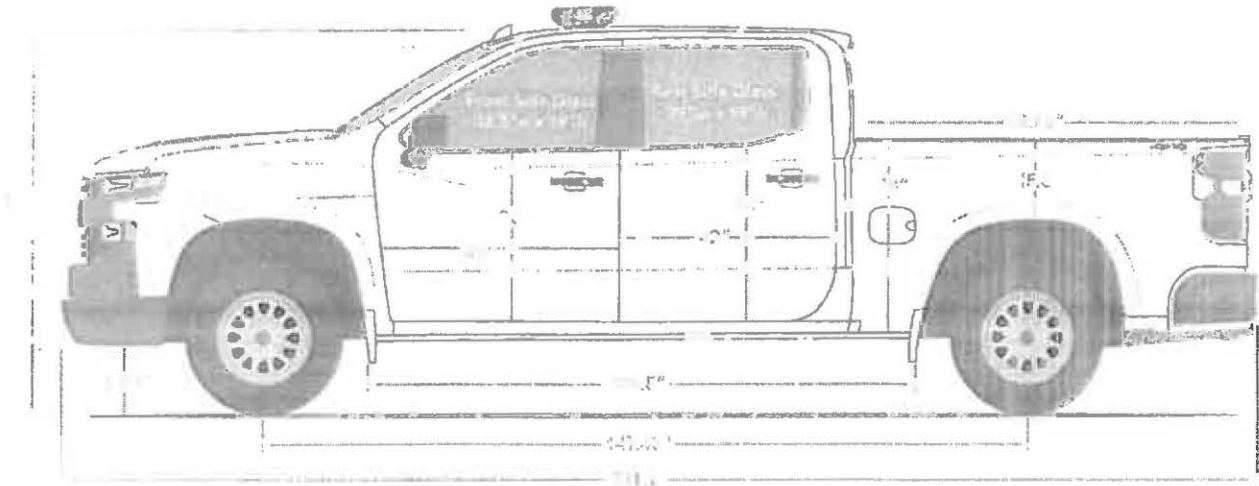

Estimated material sizes to wrap:

- Hood – 72" x 50"
- Front Doors – 50" x 36"
- Rear Doors – 45" x 37"
- Roof – 75" x 54"
- Tailgate – 69" x 26"



2019 SILVERADO 1500 SPECIAL SERVICE SW4 CREW CAB

SPECIFICATIONS

Specifications shown are for Police and Special Service Vehicles only which differ from retail civilian models

GENERAL

Model	CC10543	CK10543	CC10743	CK10743
Drive	2WD Short Box	4WD Short Box	2WD STD Box	4WD STD Box
Cab Style	Crew Cab	Crew Cab	Crew Cab	Crew Cab
Seating capacity (F/R)	3/3	3/3	3/3	3/3

*NOTE: For projected top speed, see PROJECTED TOP SPEED WITH STANDARD AND OPTIONAL TIRES Chart.

EXTERIOR (in./mm)

Wheelbase	47.43/3745	47.43/3745	156.9/3886	156.9/3886
Overall length	231.7/5885	231.7/5885	241.2/6126	241.2/6126
Body width	81.24/2063	81.24/2063	81.3/2065	81.3/2065
Overall height*	75.49/1917	75.51/1918	75.51/1918	75.51/1918
Front bumper to back of cab	150.9/3833	150.9/3833	150.9/3833	150.9/3833
Inside length of bed at floor	69.92/1776	69.92/1776	79.44/2018	79.44/2018
Inside height, bed	22.4/569	22.4/569	22.4/569	22.4/569
Inside bed width	71.4/1814	71.4/1814	71.4/1814	71.4/1814
Inside width, between wheelhousing, Fleet-side	50.63/1286	50.63/1286	50.63/1286	50.63/1286
Turning diameter, curb-to-curb, ft. (m)	46.3/14.1	46.3/14.1	49.5/15.1	49.5/14.1
Ground clearance,*	7.89/200	8.09/205	7.75/197	7.95/202

*Published dimensions do not include areal base. Curb height.

FRONT COMPARTMENT (in./mm)

Head room	43.03/1093	43.03/1093	43.03/1093	43.03/1093
Shoulder room	66.02/1677	66.02/1677	66.02/1677	66.02/1677
Hip room	61.18/1554	61.18/1554	61.18/1554	61.18/1554
Leg room	44.53/1131	44.53/1131	44.53/1131	44.53/1131

REAR COMPARTMENT (in./mm)

Head room	40.12/1019	40.12/1019	40.12/1019	40.12/1019
Shoulder room	65.16/1655	65.16/1655	65.16/1655	65.16/1655
Hip room	60.24/1530	60.24/1530	60.24/1530	60.24/1530
Leg room	43.4/1102	43.4/1102	43.82/1113	43.82/1113

*NOTE: Published dimensions indicated are without optional equipment or accessories. Additional accessories or equipment ordered at the customer's request can result in a minor change in these dimensions.

CARGO

Cargo volume, cargo box, cu. ft./liters	62.9/1781.3	62.9/1781.3	71.7/2030.5	71.7/2030.5
---	-------------	-------------	-------------	-------------

VEHICLE WEIGHT (lbs./kg.)

GVWR ² Gross Vehicle Weight Rating	6800/3084	7000/3175	6800/3084	7000/3175
FGAWR Front Gross Axle Weight Rating	3700/1678	3800/1724	3700/1678	3800/1724
RGAWR Rear Gross Axle Weight Rating	3300/1724	3800/1724	3800/1724	3800/1724
Payload ³	2030/921	2020/916	1960/889	1970/894
Base curb weight	4702/2133	4915/2229	4772/2165	4965/2752

For Box, Trailer Towing, see Standard Tires page.

PASSENGER COMPARTMENT

VOLUME INDEX (cu.ft./liters)

Interior passenger	138.6	138.6	138.6	138.6
--------------------	-------	-------	-------	-------

EPA-ESTIMATED FUEL ECONOMY RATINGS

(CITY/HIGHWAY/COMBINED)

Model	2WD Short Box	4WD Short Box	2WD Std. Box	4WD Std. Box
5.3L engine	15/21/17	15/20/17	15/21/17	15/20/17

- Cargo and load capacity limited by weight and distribution.
- Gross Vehicle Weight Rating (GVWR). When properly equipped, includes vehicle, passengers, cargo and equipment.
- These maximum payload ratings are intended for comparison purposes only. Before you buy a vehicle or use it to haul people or cargo, carefully review the vehicle loading section of the Owner's Manual or check the carrying capacity of your specific vehicle on the label on the inside of the driver's door jamb.

2019 SILVERADO 1500 SPECIAL SERVICE 5W4 CREW CAB

SPECIFICATIONS

Specifications shown are for Police and Special Service Vehicles only which differ from retail civilian models

ENGINE	STANDARD
Type	EcoTec3 V8
Displacement: liters/cu. in.	5.3/325
Horsepower/rpm	355 @ 5600
Torque lb.-ft./rpm	383 @ 4100
Induction system	Direct Injection
Compression ratio	11.0:1
Exhaust	Single
Minimum recommended fuel octane	87
Fuel capacity, approximate, gallon/liters	24/91
Oil with filter (quarts/liters)	8.5/8
Cooling capacity (quarts/liters)	17.4/16.5

TRANSMISSION	
Automatic electronic with overdrive	6-Speed
Fluid pan removed and filter replaced (quarts/liters)	6.0/5.7

AXLE	
Ratio	3.42

BRAKES	
ABS with vacuum-boost	Disc/Disc
Front-swept area (sq. in./sq. cm)	257.42/1660.76
Rear-swept area (sq. in./sq. cm)	263.74/1701.58
Total front and rear swept area (sq. in./sq. cm)	521.16/3362.32
Front rotor diameter (in./mm)	13.50/343
Rear rotor diameter (in./mm)	13.58/345
Front rotor thickness (in./mm)	1.18/30
Rear rotor thickness (in./mm)	.79/20

TIRES	
Type	All Season, Blackwall
Size	255/70R17

WHEELS	
Type	Painted Steel
Size	17"x 8"

CHASSIS	
Frame	Full perimeter steel
Front suspension	Coil over shock with 35mm twin tube shocks
Rear suspension	2-stage multi-leaf springs, semi-elliptic
Steering type	Rack and Pinion
Steering ratio	TBJ

BATTERY	
Type	Maintenance free
BCI group size	LN3
Volts	12
Amp hour rating	70
Cold cranking-amps @ 0°F (-18°C)	730

ALTERNATOR	
Type	MELCO GX9
Amps	77°F (25°C) 220

SILVERADO SSV ALTERNATOR OUTPUT

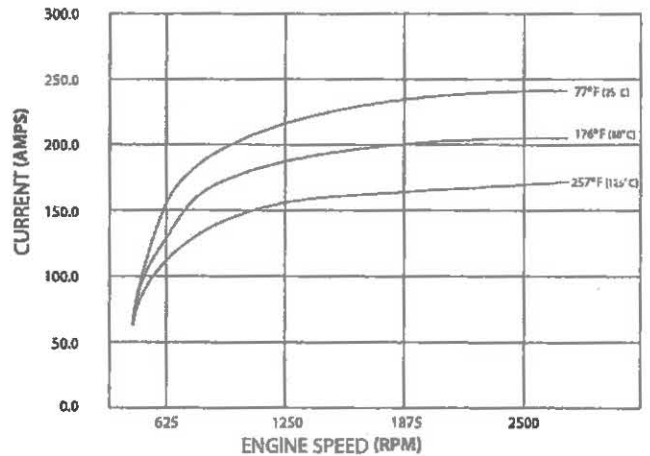

BOOST LEVEL	PARK/NEUTRAL	DRIVE
Normal Idle	550	500
1	800	650
2	800	725
3	1000	800

2019 SILVERADO 1500 SPECIAL SERVICE 5W4 CREW CAB

STANDARD TIRES - SPEED RATED

MANUFACTURER	QUANTITY	SIZE	SPEED RATING	TYPE
Random	5	255/70R17	S	All-season, BW

PROJECTED TOP SPEED WITH STANDARD AND OPTIONAL TIRES

NOTE: Adding accessories or options modified from the factory equipment may affect the projected top speed.

CODE	Tire Size	Vehicle Description	3.42 Ratio
QBN	255/70R17 (Standard)	2WD Short Box	112 mph
QDV	265/70R17 (Optional)	2WD Short Box	112 mph
RC5	LT265/70R17C (Optional)	2WD Short Box	99 mph
R30	LT275/65R18C MT DuraTrac (Optional)	2WD Short Box	99 mph
QBN	225/70R17 (Standard)	2WD Long Box	112 mph
QDV	265/70R17 (Optional)	2WD Long Box	112 mph
RC5	LT265/70R17C (Optional)	2WD Long Box	99 mph
R30	LT275/65R18C MT DuraTrac (Optional)	2WD Long Box	99 mph
QBN	225/70R17 (Standard)	4WD Short Box	112 mph
QDV	265/70R17 (Optional)	4WD Short Box	112 mph
RC5	LT265/70R17C (Optional)	4WD Short Box	99 mph
R30	LT275/65R18C MT DuraTrac (Optional)	4WD Short Box	99 mph
QBN	225/70R17 (Standard)	4WD Long Box	112 mph
QDV	265/70R17 (Optional)	4WD Long Box	112 mph
RC5	LT265/70R17C (Optional)	4WD Long Box	99 mph
R30	LT275/65R18C MT DuraTrac (Optional)	4WD Long Box	99 mph

TRAILERING SPECIFICATIONS - Automatic Transmission Ratings with Ball Hitch

Model 5.3L EcoTec3. See text for GVWR. See text for maximum hitch weight.

MODEL	AXLE RATIO	MAXIMUM TRAILER TOWING LBS. (KG)
CC10543	3.42	9800(4445)
CK10543	3.42	9500(4309)
CC10743	3.42	9700(4400)
CK10743	3.42	9500(4309)

Maximum Trailer Towing Rating is calculated based on SAE J2807 (Base vehicle plus one driver plus one passenger plus options). The weight of other optional equipment, passengers and cargo will reduce the Maximum Trailer Towing your vehicle can tow.

GCWR For Engine/Rear Axle Ratio Combination - Automatic Transmission

MODEL	(GCWR) GROSS COMBINATION WEIGHT RATINGS LBS. (KG)
(LB2) 5.3L EcoTec3	15000 (6804)

**2019 SILVERADO 1500
SPECIAL SERVICE SW4 CREW CAB**

STANDARD WHEELS



OPTIONAL WHEELS WITH DEALER INSTALLED 2" LIFT



BODY, CAGE, UNDERBODY AND FRAME MATERIAL

BODY

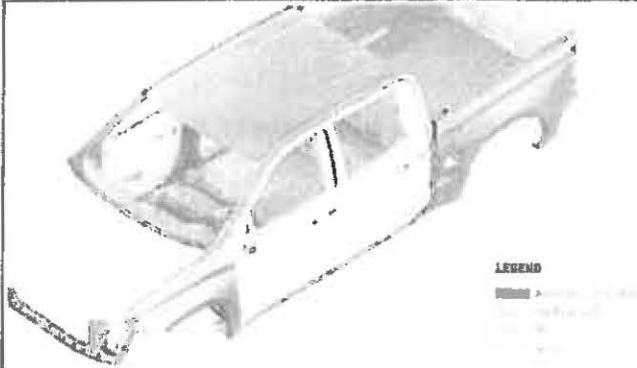

The all-new 2019 Chevrolet Silverado is up to 450 pounds lighter than the previous model through the use of mixed materials. Featuring fixed steel body components and aluminum swing panels (doors, hood, tailgate) the body is up to 88 pounds lighter.

CAGE

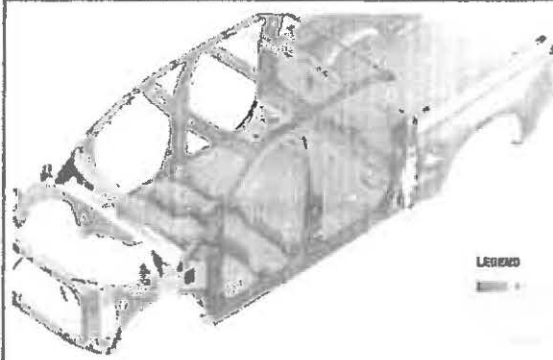

The all-new 2019 Chevrolet Silverado is 450 pounds lighter due to the extensive use of mixed materials. The underlying safety cage features significant use of advanced high strength steels, each tailored for the specific application.

UNDERBODY

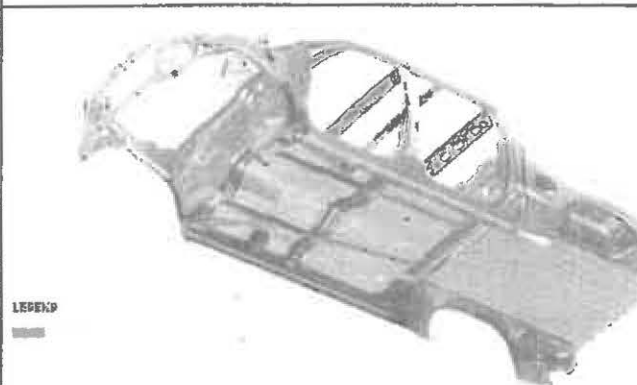

The 2019 Chevrolet Silverado is up to 450 pounds lighter than the previous model due to extensive use of mixed materials.

FRAME

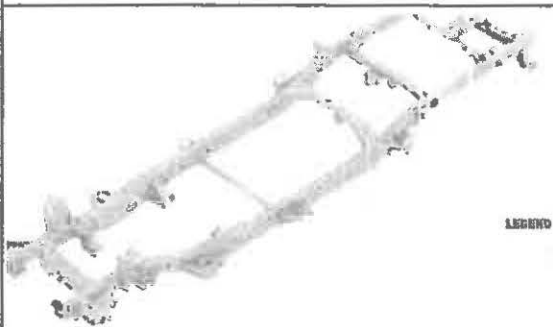

The all-new 2019 Chevrolet Silverado features a fully boxed steel frame that is 88 pounds lighter than its predecessor, while offering 10 percent greater torsional rigidity. Eighty percent of the frame is made of high-strength steel varying from 2 to 5 millimeters in thickness, and every millimeter is optimized for performance using a variety of processes, including hydroforming, roll forming, conventional stamping and tailor-rolled blanking.

STANDARD EQUIPMENT

SURVEILLANCE FEATURE 5J3 MANUAL LAMP CONTROL 9G8

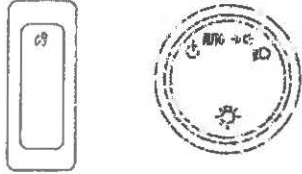

The headlamp control on the driver's side of the instrument panel operates the exterior lamps. If your Silverado does not have option 9G8, DELETE DAYTIME RUNNING LAMPS and AUTOMATIC HEADLAMPS, the Daytime Running Lamps and Automatic Headlamps can be turned OFF for one ignition cycle by rotating the headlamp control knob momentarily counter-clockwise. See your Silverado Owner's Manual.

Surveillance Feature: The Body Control Module (BCM) is calibrated to provide disabling of the exterior and interior automatic lighting. The BCM is located under the instrument panel to the left side of the steering column.

The Surveillance Feature can be activated by installing a terminated wire in cavity 21 of the Pink colored BCM connector X6. When a customer-provided terminated wire, e.g., GM #13582297, is installed in X6-21 and the wire is connected to vehicle ground via a customer switch, automatically controlled lighting is disabled or dimmed to Federally regulated level. BCM connector X6 is shown below.

Option SEO 9G8 - Delete Daytime Running Lamps and Automatic Headlamps. This option disables the Daytime Running Lamps and Automatic Headlamps control feature. Exterior lamps are only manually controlled (Option 9G8 is not available in Canada).

When the headlamp switch is in Auto with 9G8 installed, the instrument cluster, radio display and air conditioning illumination remains at daytime intensity and are dimmable only when the headlamp switch is rotated to the Parking Lamps or Headlamps positions. If SEO 9G8 is not installed, the displays are dimmable with the Headlamp switch in the AUTO position. The instrument cluster, radio and AC displays will dim if the Surveillance Feature is activated as described above.

Interior courtesy lamps, including dome lamps, can be turned OFF with a three-position switch located in the front overhead console. The interior lamp control positions are: OFF - DOOR - ON

When the switch is in the OFF position, all interior lighting remains off whenever the doors are opened.

NOTE: Wiring connection or splice changes are to be removed before the vehicle is returned to civilian use.

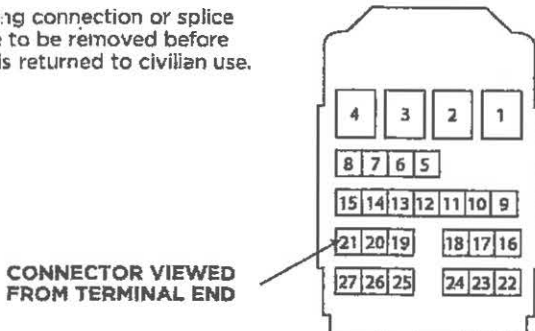

BCM Connector X6, Cavity 21

TIRE PRESSURE MONITOR WITH TIRE FILL ALERT

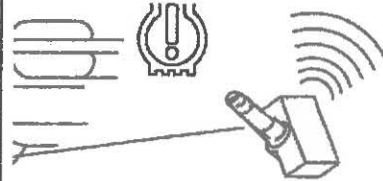

The Silverado 1500 Special Service Vehicle (SSV) 5W4 Crew Cab Package is equipped with a Tire Pressure Monitor System (TPMS) warns of low tire pressure. The Silverado SSV has an optional full size spare tire (00A) which includes a spare tire pressure sensor. When the optional spare tire from your vehicle or another SSV is placed in use as a road wheel, the TPMS will not read the presence of the new TPM sensor and must be calibrated. Refer to your owner's manual for additional information about calibration of the TPMS. See also the Tire Fill Alert feature.

SERVICE PARTS IDENTIFICATION LABEL



A Service Parts Identification (SPID) Label provides Vehicle Identification Number (VIN)-specific Option Code content list, Engineering Model Number (Nameplate, body style), Exterior paint system, Exterior paint color code and Interior trim level and color.

STANDARD EQUIPMENT

REAR VISION CAMERA

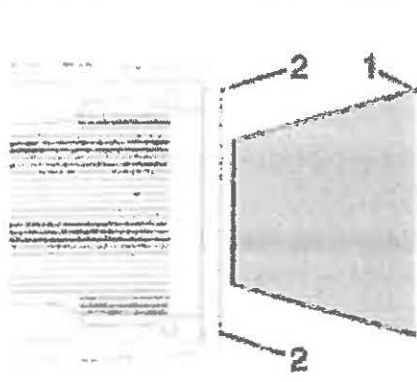

The diagram shows a side view of the rear of a vehicle. A rectangular area behind the vehicle is shaded, representing the camera's field of view. A dashed line outlines the rear bumper. A '1' points to the top-right corner of the shaded area, and '2's point to the top-left and bottom-left corners of the bumper. To the left, a portion of the infotainment screen is visible, showing a grid of icons.

1. View Displayed by the Camera in Radio Screen
2. Corners of the Rear Bumper

Displayed images may be farther or closer than they appear. The area displayed is limited and objects that are close to either corner of the bumper or under the bumper do not display.

When the vehicle is shifted into R (Reverse), the RVC displays an image of the area behind the vehicle in the center stack display. The previous screen displays when the vehicle is shifted out of R (Reverse) after a short delay. To return to the previous screen sooner, press a button on the Infotainment system, shift into P (Park), or reach a vehicle speed of 8 km/h (5 mph).

NOTE: The Rear Vision Camera will not work properly if the tailgate is down. If the tailgate is down, do not use this system.

WARNING: The camera(s) do not display children, pedestrians, bicyclists, crossing traffic, animals, or any other object outside of the camera's field of view, below the bumper, or under the vehicle. Shown distances may be different from actual distances. Do not drive or park the vehicle using only these camera(s). Always check behind and around the vehicle before driving. Failure to use proper care may result in injury, death, or vehicle damage.

OPTIONAL EQUIPMENT

V8J REAR UNDERSEAT STORAGE

Composite storage bin

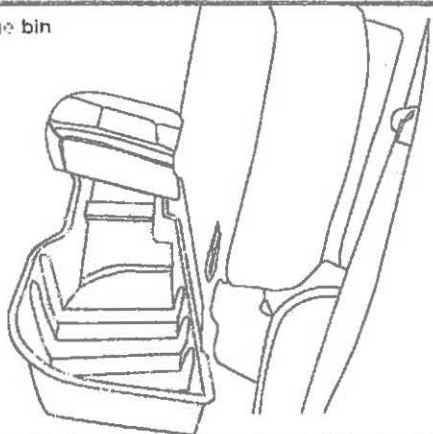

V6K SPLASH GUARDS, MOLDED

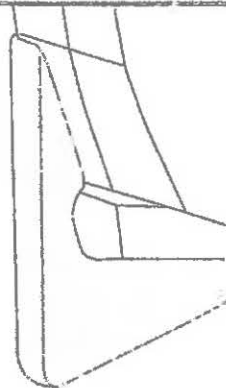

Black finish

330 REAR LAMPS FLASHING

CONNECTOR VIEWED FROM TERMINAL END

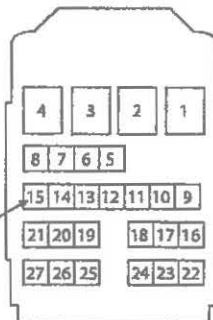

The Silverado Special Service Package has a Body Control Module (BCM) calibration which will flash the stop lamps and backup lamps to provide an alternating red - white light pattern to the rear of the vehicle. The rear lamps flashing mode is interrupted when ever the service brakes are applied.

The rear lamps flashing is activated by a customer-provided switched ground connected at the natural colored BCM connector XI, cavity 15. The rear lamps flashing feature can be operated separately or when connected to a headlamps flashing module.

NOTE: Wiring connection or splice changes are to be removed before the vehicle is returned to civilian use.

N6H AUTOMATIC TRANSFER CASE

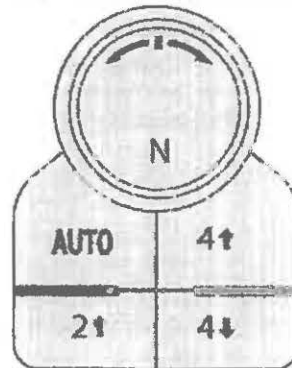

Active, 2-speed electronic Autotrac with rotary controls, includes neutral position for dingy towing. Use the transfer case knob next to the steering wheel to shift into and out of four-wheel drive.

05U WHEELS

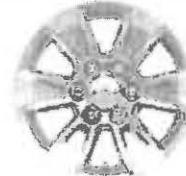

17 x 8 Bright Silver painted aluminum (Included and only available with R13 Appearance Package)

OPTIONAL EQUIPMENT

RWB BEDSIDE STORAGE BOXES

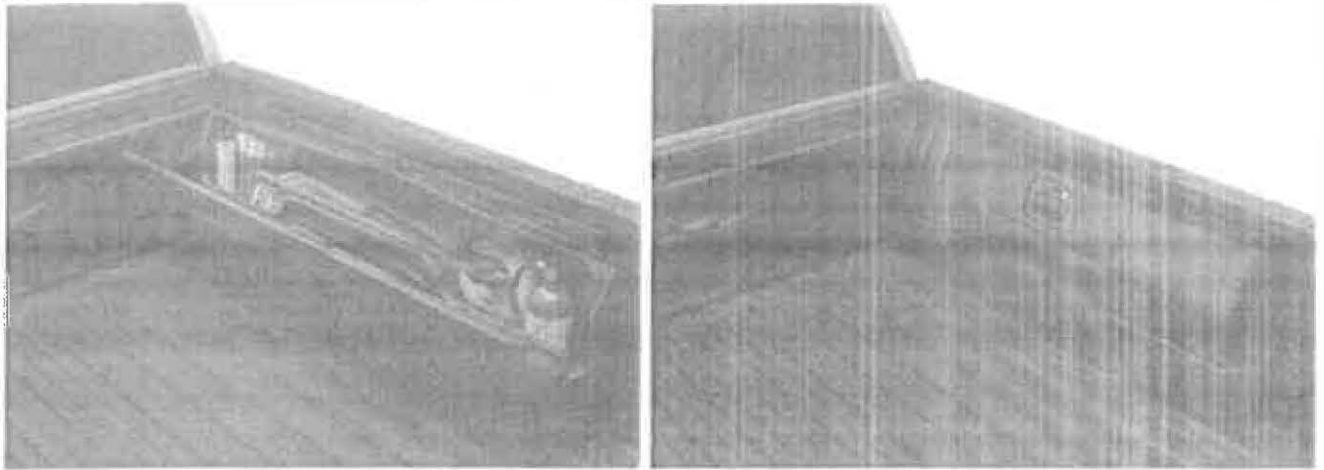

Boxes are located on the left and right side.

OPTIONAL DEALER ACCESSORIES

GM PART
15417261

REAR UNDER SEAT COMBINATION LOCK BOX

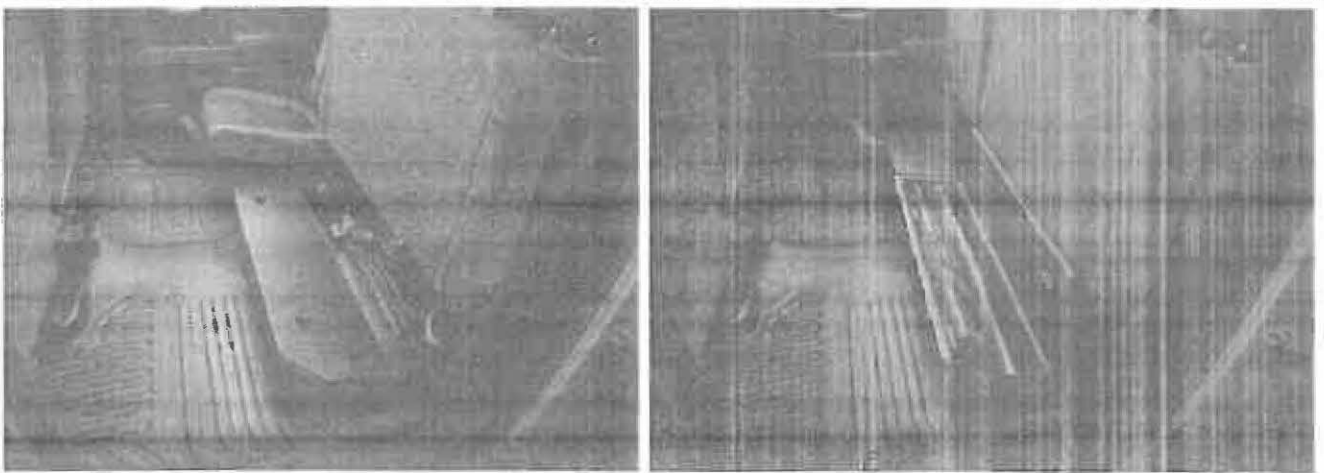

3,700 cubic inches of storage, 16-gauge steel construction, 3-digit combination with custom hook-cam. Marine-grade carpet lining with weather and dust seal. Pin-lock hinge design, no drilling required for installation.

AIRBAGS

INSTRUMENT PANEL TOP VIEW - APPROXIMATE FRONTAL AIRBAG DEPLOYMENT ZONES

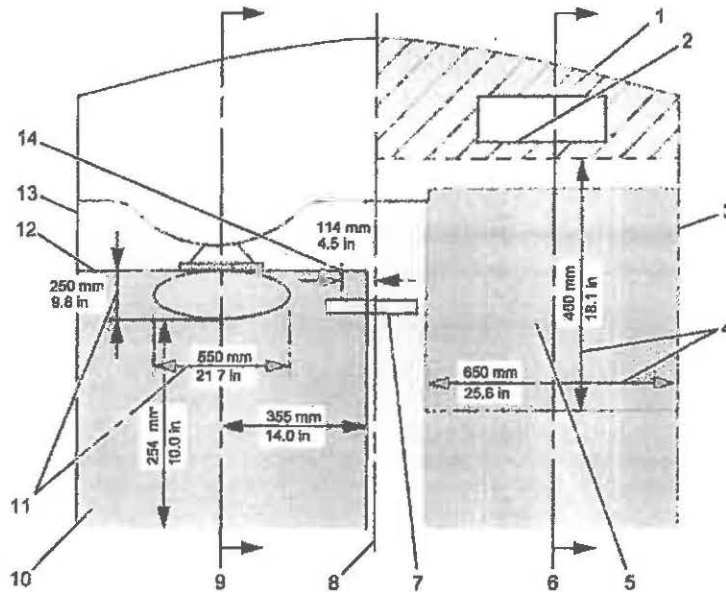

1. Passenger Side Instrument Panel Top Surface Zone
2. Frontal Outboard Passenger Airbag Module Trim Panel - Rear Edge
3. Passenger Side Door
4. Approximate Dimensions of Inflated Airbag
5. Frontal Outboard Passenger Airbag Deployment Zone
6. Passenger Centerline
7. Inside Rearview Mirror
8. Vehicle Centerline
9. Driver Centerline
10. Driver Airbag Deployment Zone
11. Driver Inflated Airbag Dimensions
12. Front of Steering Wheel (See also "Side View of Driver Frontal Airbag Deployment Zone" Following)
13. Driver Side Door
14. Shift Selector Arc

See Customer-Installed Equipment.

Sitting too close to an airbag when it deploys can increase the risk of serious injury or death. Always properly wear your seat belt. See Owner's Manual for more information

AIRBAGS

FRONT VIEW OF DRIVER INFLATED AIRBAG DEPLOYMENT ZONE

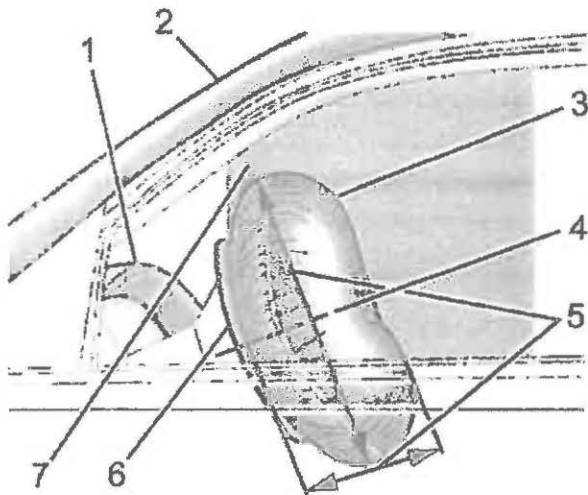

1. Top of Instrument Panel
 2. Top Edge of Windshield
 3. Inflated Airbag - Steering Wheel
 4. Centerline of Steering Column at Mid-Tilt
 5. Driver Inflated Airbag Dimensions (250 mm (9.8 in) From Front of Steering Wheel and 550 mm (21.7 in) Diameter From Center of Steering Wheel)
 6. Front of Steering Wheel
 7. Driver Airbag Deployment Zone Including Inflated Driver Airbag
- See Customer-Installed Equipment.

SIDE VIEW OF FRONTAL OUTBOARD PASSENGER AIRBAG DEPLOYMENT ZONE

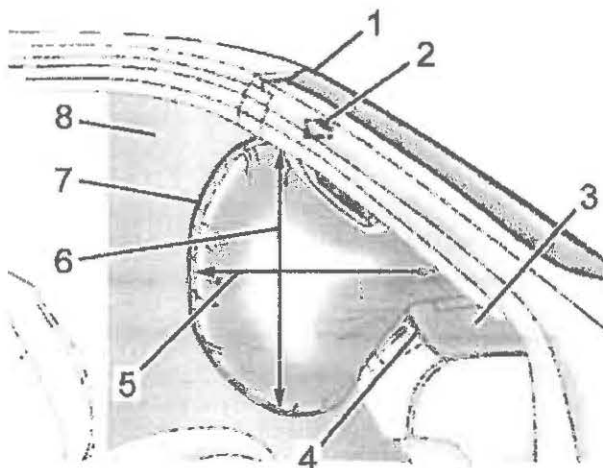

1. Top Edge of Windshield
 2. Inside Rearview Mirror
 3. Instrument Panel Top Surface Zone
 4. Frontal Outboard Passenger Airbag Module Trim Panel - Rear Edge
 5. Inflated Airbag - Horizontal Dimension (Approximately 460 mm (18.1 in))
 6. Inflated Airbag - Vertical Dimension (from Top of Occupant's Lap to Headliner)
 7. Inflated Airbag - Instrument Panel
 8. Frontal Outboard Passenger Airbag Deployment Zone
- See Customer-Installed Equipment.

Sitting too close to an airbag when it deploys can increase the risk of serious injury or death. Always properly wear your seat belt. See Owner's Manual for more information

AIRBAGS

ROOF-RAIL MOUNTED HEAD-CURTAIN AIRBAG DEPLOYMENT ZONES - FRONT PASSENGER SIDE - DRIVER AND OUTBOARD FRONT SEAT FULLY LOWERED

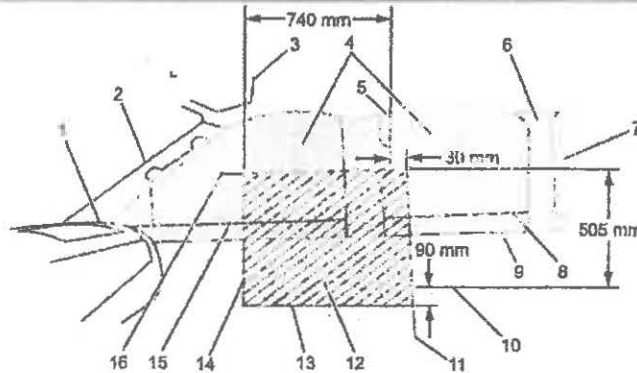

- | | |
|--|--|
| <ol style="list-style-type: none"> 1. Front of Deployment Zone at Bottom of Windshield Pillar Trim 2. A-Pillar Trim with Grab Handle (Passenger Side) 3. Sun Visor 4. Roof rail mounted head-curtain Airbag Deployment Zone - Seat Rows 1 and 2 and Cargo Area 5. Top of Roof rail mounted head-curtain Airbag Deployment Zone - Along Roof-rail at Edge of Headliner 6. C-Pillar Upper Trim 7. Rear Window 8. Top Edge of Rear Door Trim 9. Bottom Edge of Roof rail mounted head-curtain Airbag Deployment Zone at Top of Side Door Armrests 10. Top Surface of Front Seat Cushion (with Seat Fully Lowered) | <ol style="list-style-type: none"> 11. Rear Edge of Seat-Mounted Side Impact Airbag Deployment Zone (30 mm (1.2 in) Rearward of Back Edge of B-Pillar Trim Grab Handle) 12. Seat-Mounted Side Impact Airbag Deployment Zone 13. Bottom Edge of the Seat-Mounted Side Impact Airbag Zone (90 mm (3.5 in) Below Top of Seat Cushion with the Seat Fully Lowered) 14. Front Edge of Seat Mounted Side Impact Deployment Zone (740 mm (29.1 in) Forward of Back Edge of B-Pillar Trim Grab Handle) 15. Top Edge of Front Door Trim 16. Top Edge of Seat-Mounted Side Impact Deployment Zone (505 mm (19.9 in) Above Top Surface of Seat Cushion with the Seat Fully Lowered) |
|--|--|

ROOF-RAIL MOUNTED HEAD CURTAIN AIRBAG - DRIVER AND OUTBOARD FRONT PASSENGER DEPLOYMENT ZONES - VIEW FROM REAR OF VEHICLE

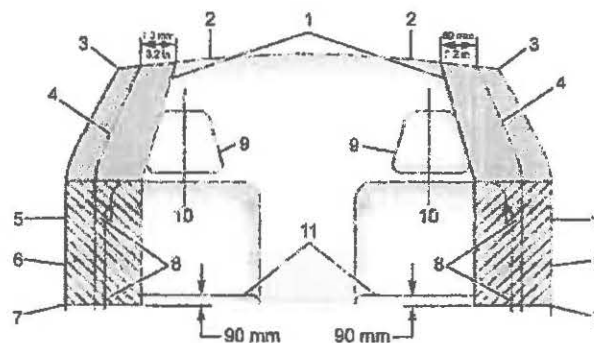

- | | |
|---|--|
| <ol style="list-style-type: none"> 1. Roof-Rail Mounted Head-Curtain Airbag Deployment Zone 2. Underside of Headliner 3. Edge of Headliner 4. Inner Center and Rear Pillar Trim 5. Inner Front and Rear Door 6. Side Door Upper Armrests and Rear Quarter Trim Armrests | <ol style="list-style-type: none"> 7. Bottom Edge of Seat-Mounted Side Impact Airbag Deployment Zone (90 mm (3.3 in) Below Top Surface of Outboard Front Seat Cushion with Seat Fully Lowered) 8. Seat-Mounted Side Impact Deployment Zone 9. Front Seat Head Restraint 10. Seat Centerline 11. Top of Seat Cushion |
|---|--|

Sitting too close to an airbag when it deploys can increase the risk of serious injury or death. Always properly wear your seat belt. See Owner's Manual for more information

AIRBAGS FAQ

Q: Can equipment such as radar devices, video cameras, and radio trees be mounted in a specialty vehicle equipped with a right front passenger frontal airbag?

A: Yes, but care must be taken to properly mount the equipment outside of the airbag "deployment zone."

Q: What is the airbag "deployment zone"?

A: The term "deployment zone" describes the space an airbag takes up when fully inflated. Airbags need room to work properly, and anything in the "deployment zone" – such as improperly mounted equipment – can greatly affect the performance of the airbag.

Q: How can I identify the airbag "deployment zone" in my vehicle?

A: See Airbag Deployment Diagrams for more information. The diagrams provide the approximate dimensions of the "deployment zones" for your specialty vehicle. Before doing any service work, including the installation of any equipment, consult the appropriate service manual.

Q: Is it possible to shield equipment so it does not interfere with airbag deployment?

A: While shielding may protect certain equipment from being damaged or dislodged, it may also negatively affect how an airbag inflates. Therefore, we cannot recommend the placement of any equipment in the deployment zone, even when shielding.

Q: Can the installation of push bumpers on the front end of the vehicle affect the deployment of the airbag?

A: It is not likely that installing push bumpers will affect sensing for the airbag as long as the vehicle structure itself is not modified. GM is not aware of any adverse defects from the many push bumpers that have been installed on current model GM police vehicles with airbags.

See "Adding Equipment to the Airbag-Equipped Vehicle" in the owner manual for more information.

Customer-Installed Equipment

Before installing equipment, read the following.

Airbags inflate with great force, faster than the blink of an eye. No objects, such as shotguns, should be placed over or near the airbag covers. Equipment mounted too close to an inflating airbag could prevent the airbag from operating properly to protect the occupants or could be forced into an occupant or break and become a dangerous projectile, causing severe injury or even death. To help prevent injury and to allow the airbag to perform as it was designed, do not mount equipment inside the airbag deployment zones.

Do not install equipment in the inflation path of any airbag. The equipment may interfere with the deployment of the airbag, may damage the airbag, or otherwise be damaged or forced into an occupant, all of which may cause severe injury or even death.

Do not attach anything to the steering wheel hub or mount any equipment within the deployment zone for the driver airbag.

Do not mount equipment on the passenger side of the instrument panel top pad deployment zone. Equipment should not be mounted on or around the passenger airbag opening because of a deploying airbag. To allow the airbag to perform as it was designed, do not mount equipment inside the airbag deployment zone.

Do not use seat accessories that block the inflation path of the driver or passenger seat-mounted side impact airbag or install equipment in the seat-mounted side impact airbag deployment zones.

Do not mount a security barrier such that the ends of the barrier or brackets are within the roof-rail airbag deployment zones.

Avoid installing wiring for roof-rail emergency lighting or radio antennas that may restrict the proper deployment of the roof-rail airbags.

Do not use seat accessories, console accessories, or other accessories that block the inflation path of the driver seat front center airbag (if equipped). Do not remove the front center console to install a police package center console, or otherwise install equipment or mount equipment between or just behind the front bucket seats on vehicles equipped with the driver seat front center airbag.

GM approved service procedures must be followed to remove and reinstall the instrument panel to the pad to ensure proper airbag deployment.

The police vehicle has a rollover sensor mounted on the centerline of the vehicle between the driver and front outboard passenger positions. If the vehicle has individual front seats, the rollover sensor will be exposed. Do not mount equipment within 25 mm (1 in) of the rollover sensor. This may affect the performance of multiple restraint system.

ELECTRONIC STABILITY CONTROL SYSTEMS (STABILITRAK)

StabiliTrak systems help drivers maintain control of their vehicles, especially during emergency lane changes or avoidance maneuvers. StabiliTrak uses various sensors, such as steering wheel angle, wheel speed, yaw velocity, etc., to detect any difference between the path requested by the steering wheel position and vehicle's actual path. When appropriate, the system selectively controls brakes, engine power, and even suspension settings to enhance control of the vehicle's direction and help keep it on course.

Independent studies conducted by the National Highway Traffic Safety Administration, the Insurance Institute for Highway Safety, and others have found StabiliTrak to be highly reactive in reducing vehicle crashes. General Motors offers StabiliTrak systems on many of its passenger car and light truck models.

See your owner's manual for additional information about the operation of StabiliTrak.

Q. How do I use StabiliTrak?

A. StabiliTrak operates independently of the driver.

You should continue to drive your StabiliTrak equipped vehicle with caution and care. GM's StabiliTrak system, StabiliTrak is designed to be as seamless as possible in operation, and part of the overall vehicle response to make a good vehicle better

Q. How does StabiliTrak work?

A. StabiliTrak has the ability to apply control forces to the vehicle independent of the driver. StabiliTrak uses sensors to continuously compare the path indicated by the steering wheel position to the vehicle's actual path. If a discrepancy is detected, StabiliTrak selectively controls vehicle brakes and engine torque to create a yaw moment that helps restore the vehicle's actual path to the path indicated by the steering wheel position. StabiliTrak has the ability to help correct both understeer (where the vehicle is not turning as much as the steering wheel position indicates) and oversteer (where the vehicle is turning more than the steering wheel position indicates).

Q. Will a tire change affect StabiliTrak?

A. Use of tires other than original equipment may affect StabiliTrak performance. StabiliTrak is designed to make the best use of available traction. The performance characteristics of the original equipment tires are part of the overall system effectiveness. When you replace tires check the recommendations in your owner's manual. On GM vehicles, the original equipment tires have a "TPC" (Tire Performance Criteria) code on the sidewall. Replacing the tires with the same "TPC" code will help assure proper StabiliTrak performance.

DRIVER OPERATED TRACTION CONTROL BUTTON

An advanced computer controlled stability enhancement system assists the driver with directional control of the vehicle in difficult driving conditions. Each time the vehicle is started, the StabiliTrak system is fully on. StabiliTrak can be controlled by a Traction Control Button. The condition system is displayed by a StabiliTrak indicator light and Driver Information

Center (DIC) Message. Push once to disable Traction Control. Push and hold to disable both Traction Control and StabiliTrak. In this condition, StabiliTrak will automatically turn ON when the vehicle speed exceeds 35 mph (56km/hr) while the Traction Control remains OFF. Push again to enable Traction Control and StabiliTrak.

MAINTENANCE / LIMITED WARRANTY

INCLUDED MAINTENANCE	One visit within first year of vehicle delivery ¹
BUMPER-TO-BUMPER LIMITED WARRANTY	3 years,/36,000 miles ² . Bumper-to-Bumper Limited Warranty with no deductible
TRANSFERABLE POWERTRAIN LIMITED WARRANTY	Qualified Fleet Customers: 5 years/100,000 miles ³
TIRES ⁴	3 years/36,000 miles ² ; coverage prorated after first 12,000 miles
ROADSIDE ASSISTANCE AND COURTESY TRANSPORTATION ⁵	Qualified Fleet Customers: 5 years/100,000 miles ³
RUST-THROUGH CORROSION	6 years/100,000 miles ²
WHEEL ALIGNMENT AND BALANCE	3 years/36,000 miles ²
	Up to 7,500 miles ⁶

1. Includes first required maintenance visit as stated in vehicle maintenance schedule. Maintenance visit consists of oil change, tire rotation and Multi-Point Vehicle Inspection. Does not include air filters. See participating dealer for other restrictions and complete details. Excludes vehicles ordered with fleet delete option RY9.

2. Whichever comes first. See dealer for limited warranty details.

3. Whichever comes first. A Qualified Fleet User is defined as a company that has purchased and registered or leased five (5) or more new cars/or trucks solely for use in its operation during the current or preceding calendar year, model year, preceding twelve (12) month period, or that owns or leases fifteen (15) or more cars and trucks. Excludes rental customers. See dealer for details.

4. Tires also covered under the Bumper-to-Bumper Warranty but are prorated based upon mileage. See dealer for warranty details.

5. If the vehicle has a warrantable failure, see your Owner's Manual for full details on the Courtesy Transportation program.

6. Customer maintenance item after 7,500 miles.



GM reserves the right to make changes at any time, without notice, in prices, colors, materials, equipment, specifications, models, and availability. Specifications, dimensions, measurements, ratings, and other numbers in this catalog and other printed materials provided at the dealership or affixed to vehicles are approximates based upon design and engineering drawings and prototypes and laboratory tests. Your vehicle may differ due to variations in manufacture and equipment. Since some information may have been updated since the time of printing, please check with your GM dealer for complete details. Some of the equipment shown or described throughout this publication may be available at extra cost, and/or is supplied by an independent supplier.

Copyright 2018 General Motors. All rights reserved. All text, images, graphics, and other materials in this publication are subject to the copyright and other intellectual property rights of General Motors. These materials may not be reproduced, distributed, or modified without the express written permission of General Motors. The marks appearing in this publication including, but not limited to: GM and the GM logo; Chevrolet and their respective logos, emblems, slogans, and vehicle model names and body designs; and other marks such as GM Fleet and Commercial are trademarks and/or service marks of General Motors, its subsidiaries, affiliates, or licensors.

For more detailed information, contact your District Sales Manager or see the online order guide at gmfleet.com/police.

GENERAL MOTORS FLEET



LINCOLN POLICE DEPARTMENT

CHIEF PAUL ADAMS



DEPUTY CHIEF MATT VLAHOVICH

TOTAL
9 UNITS
\$ 11800

Appendix A
Trade In Vehicles

Year	Make	Model	Mileage	VIN
2008	Ford	Crown Victoria Police Interceptor	124,982 miles	2FAFP71V18X180424
Notes:	Blue, 4 Door, 4.6 L V-8 Motor			
Trade In Value		\$ 600 ⁰⁰		

Year	Make	Model	Mileage	VIN
2010	Ford	Crown Victoria Police Interceptor	109,000 miles	2FABP7BV7AX112874
Notes:	Black, 4 Door, 4.6 L V-8 Motor			
Trade In Value		\$ 1100 ⁰⁰		

Year	Make	Model	Mileage	VIN
208	Ford	Crown Victoria Police Interceptor	171,041 miles	2FAFP71V68X128934
Notes:	Black & White, 4 Door, 4.6L V-8 Motor. New motor was installed at 75,000 miles.			
Trade In Value		\$ 600 ⁰⁰		

LINCOLN POLICE DEPARTMENT

CHIEF PAUL ADAMS



DEPUTY CHIEF MATT VLAHOVICH

(7)

Year	Make	Model	Mileage	VIN
2009	Ford	Crown Victoria Police Interceptor	162,000 miles	2FAHP71V99X139632
Notes:	Black & White, 4 Door, 4.6L V-8 Motor			
Trade In Value	\$ 900 ⁰⁰			

Year	Make	Model	Mileage	VIN
2010	Ford	Crown Victoria Police Interceptor	80,000 miles	2FABP7BV3AX131955
Notes:	Black & White, 4 Door, 4.6 L V-8 Motor			
Trade In Value	\$ 1100 ⁰⁰			

Year	Make	Model	Mileage	VIN
2008	Ford	Explorer	88,000 miles	1FMEU73E18UB17967
Notes:	Brown, 4 Door, 4.0L V-6 Motor			
Trade In Value	\$ 1600 ⁰⁰			

Year	Make	Model	Mileage	VIN
2008	Dodge	Charger	99,000 miles	2B3KA43G78H217902
Notes:	Black, 4 Door Sedan, 3.6L V-6 Motor			
Trade In Value	\$ 600 ⁰⁰			

LINCOLN POLICE DEPARTMENT

CHIEF PAUL ADAMS



DEPUTY CHIEF MATT VLAHOVICH

3

Year	Make	Model	Mileage	VIN
2012	Dodge	Charger	83,000 miles	2C3CDXAG3CH126508
Notes:	Black, 4 Door Sedan, 3.6L V-6 Motor			
Trade In Value		\$ 2200 ⁰⁰		

Year	Make	Model	Mileage	VIN
2013	Dodge	Charger	58,000 miles	2C3CDXAG9DH734664
Notes:	Navy Blue, 4 Door Sedan, 3.6L V-6 Motor			
Trade In Value		\$ 3100 ⁰⁰		

CITY CLERK
LINCOLN, ILLINOIS

JUN 11 2019

RECEIVED

A. Davis

1:50 p.m.

City of Lincoln Police Department, RFP: 8 New Patrol Vehicles

Graue Inc.

1905 N. Kickapoo St.

Lincoln, IL 62656

Franchise dealer of Chevrolet, Buick and Cadillac

Contact:

Dave Renfro, New Vehicle Sales Manager

217-735-4444

ORDINANCE NO. _____
AN ORDINANCE AMENDING TITLE 3 SECTION 15 OF
THE LINCOLN CITY CODE

THIS ORDINANCE is made and adopted by the CITY COUNCIL OF THE CITY OF LINCOLN, LOGAN COUNTY, ILLINOIS, at a regular meeting held in the City Council Chambers in said City on the ____ day of _____, 2019, WITNESSETH:

WHEREAS, the CITY OF LINCOLN is a municipal corporation located in Logan County, Illinois; and

WHEREAS, the CITY OF LINCOLN acknowledges that State Statute has been amended to raise the legal age for the sale and distribution of nicotine and alternative nicotine products effective July 1, 2019; and

WHEREAS, the CITY OF LINCOLN feels that it is in the best interests of local health, safety, and morality that the city retains a civil fine for those under the legal age who are found in possession of nicotine products and alternative nicotine products; and

WHEREAS, the CITY OF LINCOLN that it is the best interest of local health, safety, and morality that City of Lincoln comport with state statute thereby raising the legal age to sell and possess nicotine and alternative nicotine products to 21; and

NOW, THEREFORE, IT IS HEREBY RESOLVED by the CITY COUNCIL OF THE CITY OF LINCOLN, as follows:

1. The City of Lincoln will amend Title III Chapter 15 Part 1 of the Lincoln City Code to change the legal age of sale and possession of nicotine products and alternative nicotine products to the age of 21 (See below Exhibit).
5. Effective Date. That this Ordinance is effective July 1, 2019.

The vote on the adoption of his Resolution was as follows:

Alderman Parrott	_____	Alderman Keller	_____
Alderwoman Horn	_____	Alderman Welch	_____
Alderman Hoinacki	_____	Alderwoman Schmidt	_____
Alderman Downs	_____	Alderman Bateman	_____

Ayes: _____

Nays: _____

Abstain: _____

Absent: _____

Passed and approved this ____ day of _____, 2019.

CITY OF LINCOLN,

BY: _____

Seth Goodman, Mayor
City of Lincoln, Logan County, Illinois

ATTEST: _____ (SEAL)

City Clerk, City of Lincoln,
Logan County, Illinois

EXHIBIT A

3-15-1: SALE, USE AND POSSESSION OF TOBACCO PRODUCTS AND ALTERNATIVE NICOTINE PRODUCTS:

- (A) **Providing Tobacco Products and Alternative Nicotine Products To a Minor:** It shall be unlawful for any person, whether acting individually, or as an owner, officer, employee or agent of, or on behalf of, any person to sell, buy for, distribute samples of, furnish, exchange or give away any tobacco or alternative nicotine products in any form to any individual under the age of twenty-one (21) years.
- (B) **Before selling, offering for sale, giving, or furnishing tobacco or alternative nicotine products, or any cartridge or component of tobacco or alternative nicotine products, to another person, the person selling, offering for sale, giving, or furnishing the products shall verify that the person is at least 21 years of age by:**

 - (1) examining from any person that appears to be under 27 years of age a government-issued photographic identification that establishes the person is at least 21 years of age or
 - (2) for sales made through the internet or other remote sales methods, performing an age verification through an independent, third-party age verification service that compares information available from public records to the personal information entered by the person during the ordering process that establishes the person is 21 years of age or older.
- (C) **Possession of Tobacco Products and Alternative Nicotine Products By A Minor:** No individual under the age of twenty-one (21) years of age shall have in his or her possession or use any tobacco product or alternative nicotine product in any of its forms. It shall not be a violation of this section for any such person to have in his or her possession or use of any tobacco products or alternative nicotine products while in the presence of his or her parents or legal guardian, or in the performance of a religious ceremony.

ORDINANCE NO. 2019-_____

ORDINANCE ADOPTING AMENDMENT #1 TO APPROPRIATION ORDINANCE

CITY OF LINCOLN

May 1, 2018 - April 30, 2019

WHEREAS, the City Council has directed the Corporate Authorities to prepare an Appropriation Ordinance; and

WHEREAS, the Corporate Authorities worked diligently in the preparation of The Appropriation Ordinance for the fiscal year beginning May 1, 2018 and ending April 30, 2019; and

WHEREAS, the City Council desires to limit the spending of the City according to those items as set forth in the Working Appropriation Ordinance unless approved by the Council; and

WHEREAS, the total Budget expenditures and Appropriation expenditures for the fiscal year beginning May 1, 2018 and ending April 30, 2019 will not be exceeded as a result of the Appropriation changes described herein;

NOW THEREFORE, it is hereby resolved that the amendments within the Appropriation, as proposed by the Corporate Authorities on June 17, 2019, as attached and incorporated herein, are hereby adopted as a spending limit for the items contained therein and before expenditures shall be made in excess for items not contained therein, it shall be necessary to apply to the City Council for a modification of the Appropriation Ordinance. This Ordinance shall be in effect the 17th day of June, A. D. 2019.

This Ordinance shall be in full force and effect from and after its passage, approval and publication in pamphlet form as provided by law.

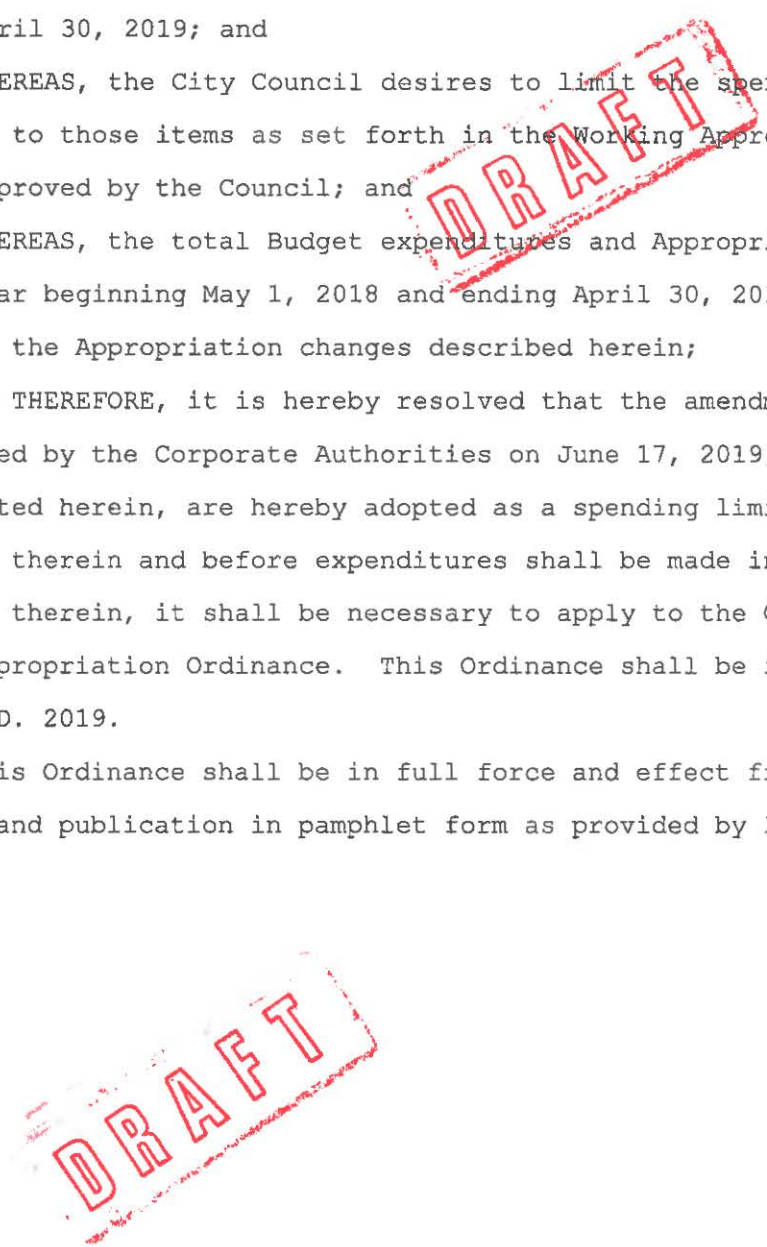

Amendment To Appropriations Ordinance
Fiscal Year 2018-2019

<u>Amount</u>	<u>From:</u>	<u>To:</u>
\$ 4,900.00	02-0018-8387 Liability Insurance	02-0018-8385 Vehicle Liability Insurance
\$ 35,250.00	02-0018-8388 Workmen's Compensation	02-0018-8389 Insurance-Property
\$ 2,500.00	02-0204-5112 City Clerk-Travel & Training	02-0204-6435 City Clerk-Contractual Services
\$ 400.00	02-0214-4012 City Admin. Salaries	02-0214-4012 City Admin./Office Supplies
\$ 1,000.00	02-0214-4012 City Admin. Salaries	02-0214-8474 City Admin./Telephone/Internet/Fax
\$ 2,100.00	02-0604-6435 Copier Lease/Contract. Services	02-0604-5414 JULIE Fees
\$ 10,500.00	02-0604-6438 Contingencies/Communication	02-0604-6439 Contingencies/Software Maintenance
\$ 575.00	02-0800-8650 Fire Dept.-Medical Supplies	02-0806-8474 Fire Dept.-Telephone/Mobil/Pagers
\$ 400.00	02-1200-8402 Police Dept.-Dues/Subscriptions	02-1200-8474 Police Dept.-Telephone/Fax
\$ 1,500.00	02-1400-6433 Bldg. & Grounds-Internet	02-1400-6435 Bldg. & Grounds-Contractual Services
\$ 6,000.00	02-3600-5202 Streets & Alleys-Repairs/Equip.	02-3600-5214 Streets & Alleys-Capital Equipment
\$ 550.00	02-3600-8650 Streets & Alleys-Med. Exams	02-3600-8474 Streets & Alleys-Telephone/Mobil/Pagers
\$ 6,825.00	02-3600-6446 Streets & Alleys-St. Markings	02-3600-5230 Streets & Alleys-Repairs/St. Lights
\$ 11,500.00	02-3606-4014 St. & Alleys-Salaries/Hourly	02-3606-4016 St. & Alleys-Salaries/Part-Time
\$ 26,000.00	20-0000-5116 M.F.T./Supplies, Materials	20-0006-4014 M.F.T./Salaries-Hourly
\$ 2,700.00	20-0000-5116 M.F.T./Supplies, Materials	20-0006-4018 M.F.T./Salaries-Hourly
\$ 5,100.00	50-7004-8410 Sewer Admin./Salaries-Monthly	50-7004-5102 Sewer Admin./Supplies-Offic

\$	150.00	55-0000-7011 Hotel/Motel Tax/Addtl. Events	55-00007003 Hotel/Motel Tax/Tropics Sign
----	--------	---	---

Amount

Revenue

\$	60,000.00	60-0001-3796 Loan Proceeds
----	-----------	-------------------------------

Expenditure

60-0200-7815 Land Acquisition

Amount

From:

To:

\$	9,300.00	60-0200-7850 Participation/Lincoln Pkwy.	60-0200-7815 Land Acquisition
\$	15,000.00	60-3600-7850 Participation/Lincoln Pkwy.	60-3600-78852 Jefferson St. Bridge Design
\$	195,000.00	60-0200-7820 Public Safety Bldg. Financing	60-0007-8822 Bond Principal
\$	92,450.00	60-0200-7820 Public Safety Bldg. Financing	60-0007-8832 Bond Interest
\$	750.00	60-0200-7820 Public Safety Bldg. Financing	60-0007-8842 Bond Service Fees



\$	1,400.00	76-0000-8600 Firefighter's Pension, Misc.	76-0000-8420 Firefighter's Pension/Professional Fees
----	----------	--	---



The vote on the adoption of this Ordinance was as follows:

Ald. Parrott _____
Ald. Downs _____
Ald. Keller _____
Ald. Hoinacki _____

Ald. Welch _____
Ald. Schmidt _____
Ald. Bateman _____
Ald. Horn _____

Ayes: _____

Nays: _____

Absent: _____

Abstentions: _____

Passed and approved this _____th day of _____, 2019.

City of Lincoln,

BY: _____

Seth A. Goodman, Mayor
City of Lincoln,
Logan County, Illinois

ATTEST; _____ (SEAL)

Peggy S. Bateman, City Clerk
City of Lincoln,
Logan County, Illinois



SETH A. GOODMAN
MAYOR

ELIZABETH KAVELMAN
CITY ADMINISTRATOR

PEGGY S. BATEMAN
CITY CLERK

CHARLES N. CONZO
CITY TREASURER

JOHN A. HOBLIT
CITY ATTORNEY



CITY OF LINCOLN, ILLINOIS

700 Broadway St., P.O. Box 509, Lincoln, IL 62656

Named for and Christened by Abraham Lincoln, 1853—Incorporated February 16, 1865
CITY COUNCIL MEETS FIRST AND THIRD MONDAY NIGHTS EACH MONTH

June 10, 2019

Mayor Seth Goodman
City Administrator Elizabeth Kavelman
City Clerk Peggy Bateman
City Attorney John Hoblit
Ald. Steve Parrott, Ald. Tracy Welch, Ald. Sam Downs, Ald. Kathryn Schmidt,
Ald. Kevin Bateman, Ald. Ron Keller, Ald. Jeff Hoinacki and Ald. Kathy Horn

Dear City Officials:

As you know, a working budget document is adopted for each fiscal year by the City Council in the form of a Resolution which is adopted prior to the beginning of the fiscal year. The purpose of this Resolution is to project our best estimates of revenues for the ensuing fiscal year and, to describe in detail, a plan for expenditures for each fund, sub-fund and expenditure line.

Further, our city is governed by an annual Appropriation Ordinance which is enacted during the first quarter of each fiscal year. The purpose of this ordinance is to reaffirm, certify and, if necessary, to correct our revenue estimates and to set limits for spending by the city for each fund, sub-fund and, to the extent possible, for each expenditure line.

As in past years, the City may also enact Ordinances Amending the Appropriation Ordinance, if and when additional sources of revenue become available, or in those cases where expenditures for a specific line exceed the amount specified in the original Appropriation Ordinance. Such amendments may be enacted to transfer unused expenditure amounts from lines in which the Appropriation amount exceeds the actual expenditures to lines within the same fund in which expenditures have exceeded the amount specified in the original Appropriation Ordinance.

Unfortunately, during the preceding fiscal year we have encountered a situation within our Building & Grounds Fund where our expenditures have exceeded our Appropriation for this fund. As a result, it is not possible to amend the Appropriation Ordinance within the Building & Grounds Fund, as described above, because the amount of expenditures that exceeds the Appropriation in certain lines exceeds the total of funds available in the other lines within the same fund. Please refer to the attachment which describes the above situation in greater detail.

There are several factors which should be noted in regards to the above problem. First, the lines where our expenditures have exceeded our Appropriation are utility costs and the cost of the contract for custodial services. Second, it is important to note that F.Y. 2018-2019 was the first year during which we had incurred significantly increased utility and custodial expenses for additional buildings which have been added

CITY COUNCIL

(continued)

FIRST WARD
STEVE PARROTT
TRACY WELCH

SECOND WARD
KATHRYN SCHMIDT
SAM DOWNS

THIRD WARD
KEVIN BATEMAN
RON KELLER

FOURTH WARD
JEFF HOINACKI
KATHY HORN

(continued from previous page).

to the assets of the city. Third, we correspondingly increased our budget for these lines for F.Y. 2019-2020 in order to remedy this situation. Fire Chief Mark Miller (Ret.) worked diligently, prior to his retirement, to calculate the costs for these lines for the current fiscal year. His efforts should result in a budget and Appropriation which more accurately reflects the amounts that we will spend for these lines in the year ahead.

It is also significant to note that these additional expenditures, while somewhat greater than in previous years, are outweighed by the benefits gained by the addition of these buildings which are tremendous assets to our city. In addition, these increased costs are offset, in part, by savings in other lines within our budget, the elimination of other expenditure lines and by the increased revenue generated by these assets. Also, these assets have made it possible to address several long-term problems faced by our city and they enable our city to operate more efficiently and with greater effectiveness.

Finally, it is very important to note that our General Fund expenditures for F.Y. 2018-2019 were far below both our budget and our Appropriation Ordinance requirements.

As always, if you need further clarification or more information, please contact me.

Sincerely,

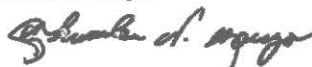

Charles N. Conzo
City Treasurer

cc: Police Chief Paul Adams
Fire Chief Bob Dunovsky
Supt. Walt Landers
Supt. Wes Woodhall
Supt. Greg Pyles
City Council Secretary Alex Williams

Encl: (1)

**Contingency Fund--Budget/Appropriation/Expenditures
F.Y. 2018-2019**

Bulding & Grounds

02-1400--Selected Lines

		2018-2019	2018-2019	2018-2019	2019-2020
		Budget	Appropriation	Expenditures	Budget
02-1400-6430	Custodian Contract	\$ 18,500.00	\$ 20,000.00	\$ 30,940.00	\$ 30,000.00
02-1400-8302	Utilities--Electric	\$ 10,000.00	\$ 15,000.00	\$ 46,790.77	\$ 50,000.00
02-1400-8304	Utilities--Gas	\$ 5,000.00	\$ 8,000.00	\$ 10,793.68	\$ 12,000.00